

MUELLER® GAS

Shur Stop™ Unit 68 PE Line Stopping System

6" – 8"

SDR 11 - 11.5 - 13.5

Form 13932 – 10/2024

⚠ WARNING:

1. Read and follow instructions carefully. Proper training and periodic review regarding the use of this equipment is essential to prevent possible serious injury and/or property damage. The instructions contained herein were developed for using this equipment on fittings of Mueller manufacturer only, and may not be applicable for any other use.
2. Do not exceed the pressure ratings of any components or equipment. Exceeding the rated pressure may result in serious injury and/or property damage.
3. Safety goggles and other appropriate protective gear should be used. Failure to do so could result in serious injury.
4. Pressure test, check for and repair leaks in all fittings and components each time one is installed or any joint or connection is broken. Failure to find and repair a leak from any source in the fittings, by-pass lines or equipment could result in an explosion and subsequent serious injury and/or property damage.
5. MUELLER® Drilling Machines and Equipment have been carefully designed and engineered to work together as a unit. The use of equipment manufactured by someone other than Mueller Co. may cause excessive wear or a malfunction of the MUELLER machines.

TABLE OF CONTENTS	PAGE
General Information	2
Equipment, Parts and Dimensions	3-5
Operating Instructions	6-12
Completion Plug Extraction Instructions	13-14
Troubleshooting and Storage	15

MUELLER

Customer Service Center
Decatur, Illinois
800.798.3131
www.muellergas.com
moreinfo@muellercompany.com

All warranties, expressed or implied, for Mueller Drilling Machines are rendered null and void if the machines are used with shell cutters or equipment manufactured by someone other than Mueller Co.

MUELLER® Shur Stop™ Unit 68 PE Line Stopping System

General Information and Equipment

OVERVIEW

The Shur Stop PE stopping system allows NO BLO stopping operations on 6" and 8" (SDR 11 - 11.5 - 13.5) polyethylene pipes operated up to a maximum operating pressure of 125 psig (Actual MAOP will be dependent on the operating pressure of the PE pipe).

This manual describes all operations including drilling, stopping and completion plug insertion.

Basic Equipment Required

1. Electrofusion Fitting
2. Centering Clamp
3. Slide Gate Valve
4. Stopping Machine
5. Cleaning / Inspection Machine
6. Combination Drilling / Completion Machine

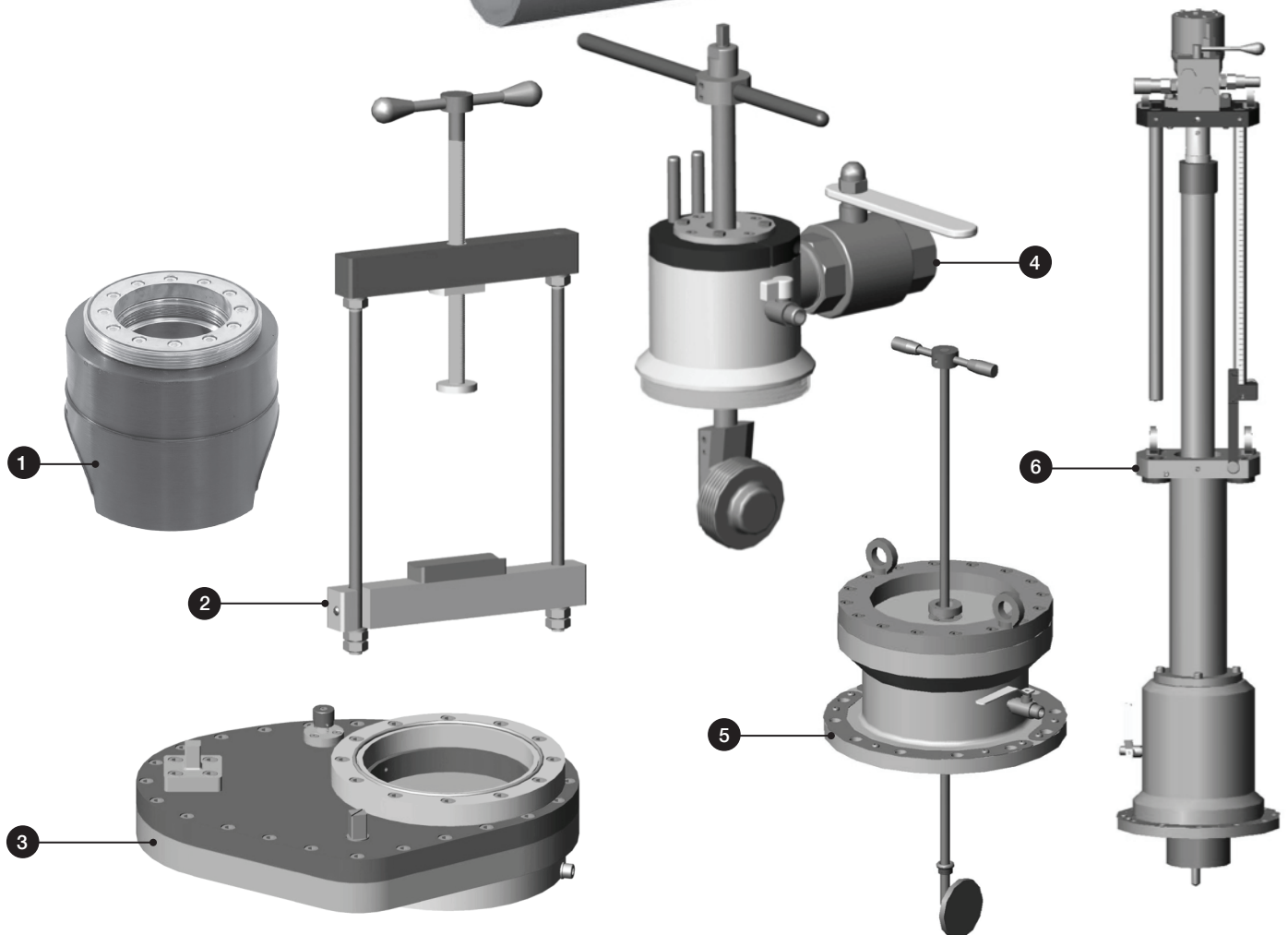
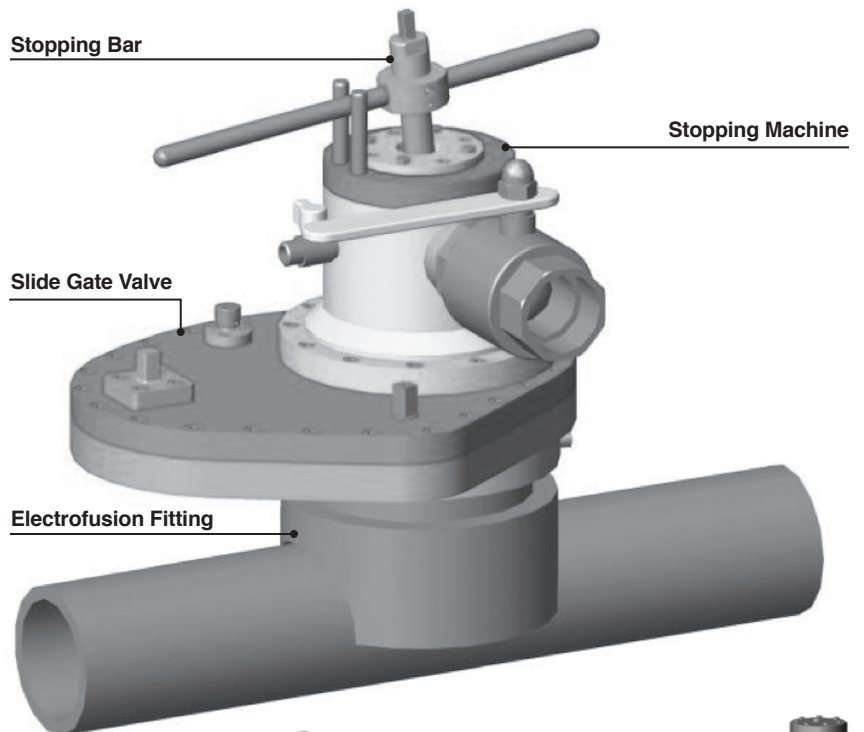

MUELLER® Shur Stop™ Unit 68 PE Line Stopping System

Equipment, Parts and Dimensions

EQUIPMENT

1. Electrofusion Fitting

Each fitting is composed of:

- Electrofusion housing with metal bushing.
- Completion Plug with two O-rings.
- Completion Cap with one O-ring.

NOTE: These fittings are compatible with any universal processor available on the market equipped with a barcode pen/ scanner.

Electrical Parameters

- Frequency of power supply current 50 Hz
- Output voltage 8 V – 48 V

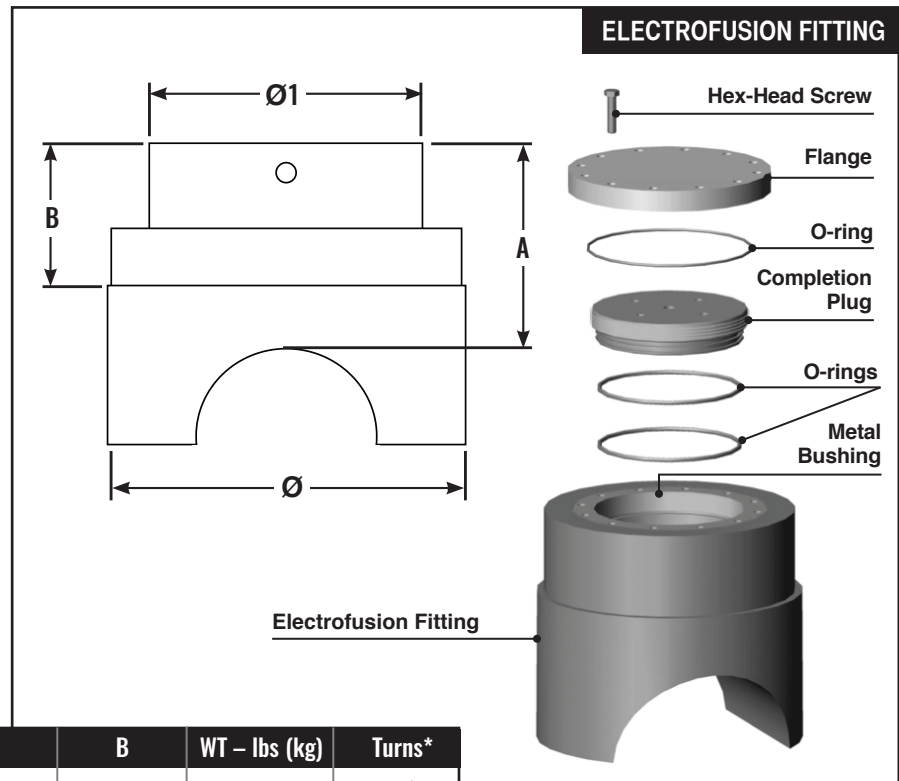

DIMENSIONS – Inches (mm)

PE PIPE	Ø	Ø1	A	B	WT – lbs (kg)	Turns*
6"	10.24 (260)	7.64 (194)	5.90 (150)	4.33 (110)	57.3 (26)	5 ± 1/4
8"	13.00 (330)	9.76 (248)	7.59 (193)	5.62 (143)	100.0 (45)	4 1/4 ± 1/4

*Number of revolutions to install completion plug

2. Centering Clamp for Electrofusion Fittings

The Centering Clamp is used to properly align the Electrofusion Fittings to the pipe during the fusion process. It is designed to evenly distribute the clamping force applied by the operator.

DIMENSIONS – Inches (mm)

L	W	H	WT – lbs (Kg)
16.57 (421)	1.97 (50)	36.49 (927)	35.27 (16)

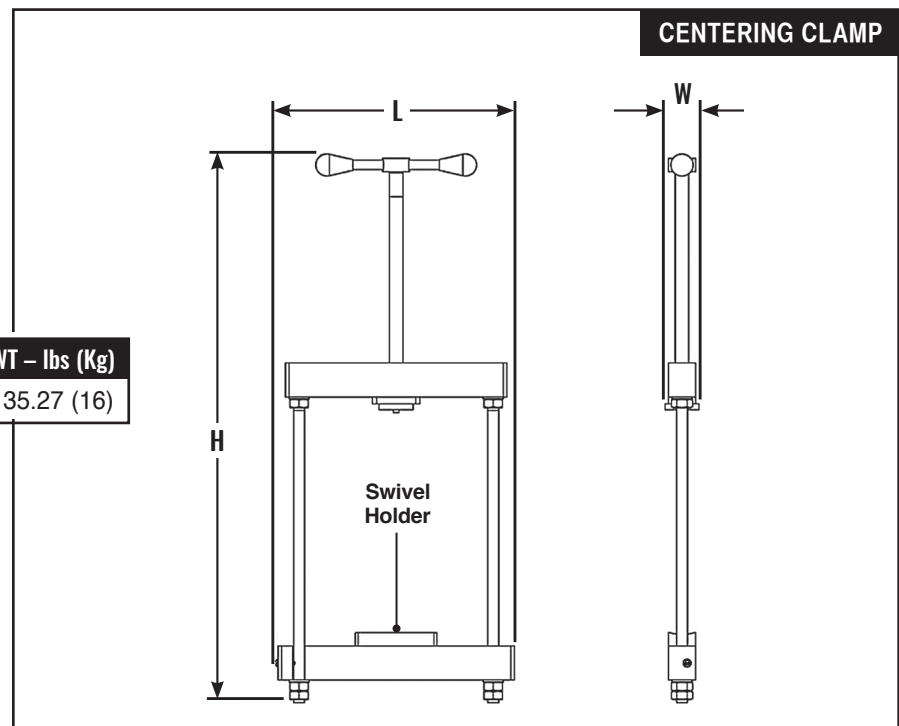

MUELLER® Shur Stop™ Unit 68 PE Line Stopping System

Equipment, Parts and Dimensions

3. Slide Gate Valve

The Slide Gate Valve consists of a sliding gate housed between two flat bodies; pressure is held firmly by two O-rings, one above and one underneath. The valve is fitted with an internal pressure equalizer which allows easy opening when pressure varies between the upper and lower parts of the valve. To open and close the valve, turn the operating square approximately a quarter turn.

⚠ CAUTION: Never leave the valve with the gate in the closed position when not in use. In the event that the gate is stuck, loosen the screws holding the two valve bodies, bring the gate to the open position and retighten the screws.

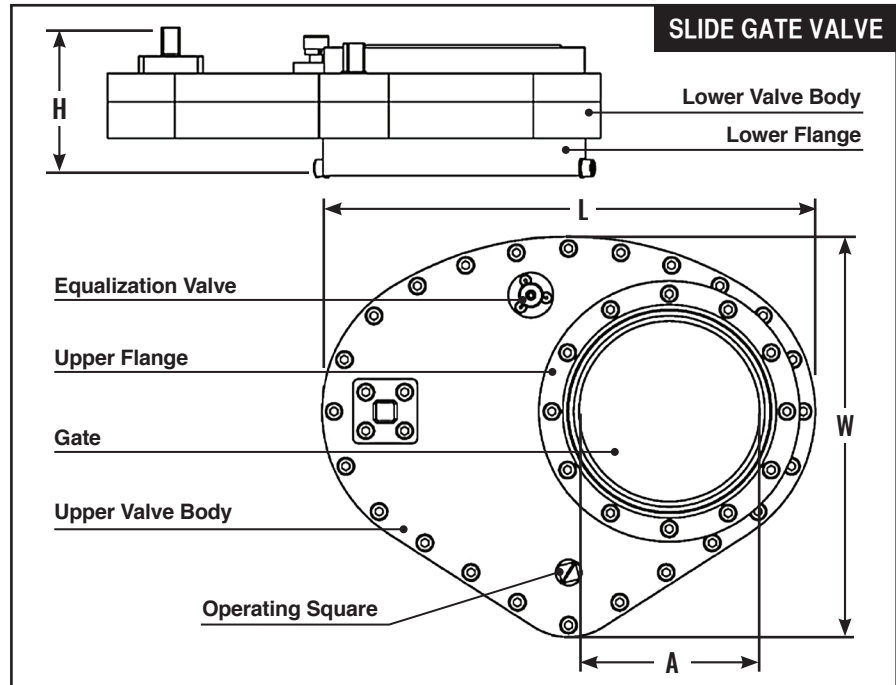

DIMENSIONS – Inches (mm)

PE PIPE	L	W	H	PASSAGE ØA	WT – lbs (Kg)
6" – 8"	21.25 (540)	16.41 (417)	6.73 (171)	7.67 (195)	77.1 (35)

4. Stopping Machine

The Stopping Machine is composed of:

- A stopping machine with bypass valve, bleed valve and available gas source (equalizer);
- An expanding stopper consisting of two flanges.

On the upper part of the stopping bar there is an operating square that when turned (**clockwise**) the two flanges compress resulting in the expansion of the sealing ring.

The result is full contact between the sealing ring and the inner wall of the pipe, ensuring complete gas control. The affect is 100% stop off.

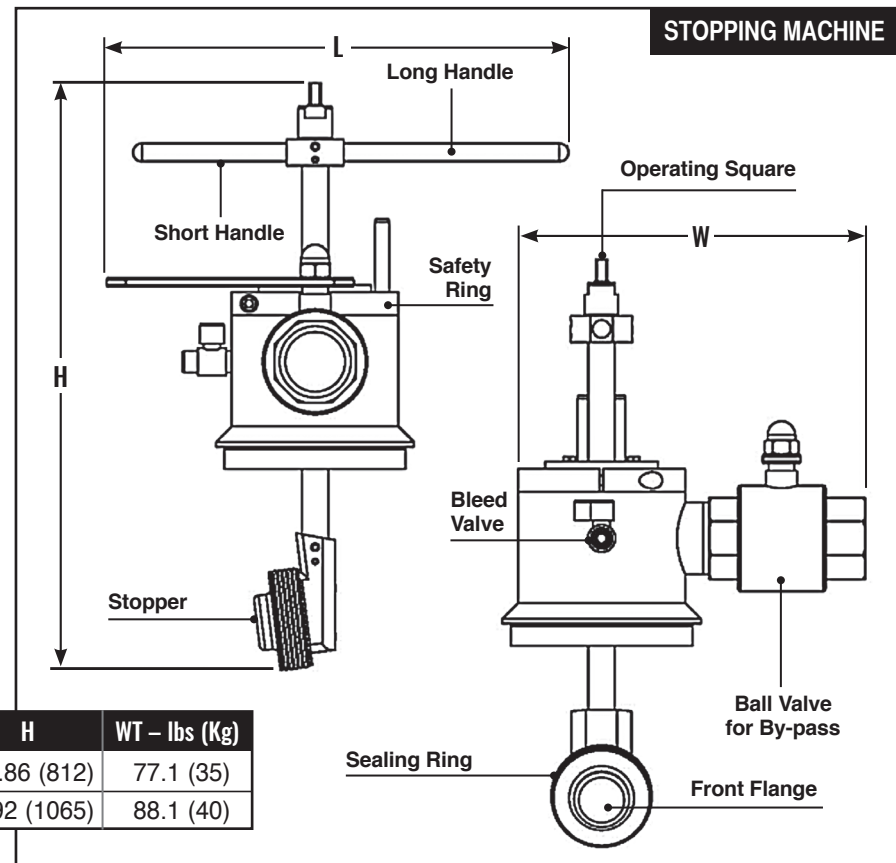

DIMENSIONS – Inches (mm)

PE PIPE	L	W	H	WT – lbs (Kg)
6"	20.86 (530)	15.74 (400)	31.86 (812)	77.1 (35)
8"	22.91 (582)	16.25 (413)	41.92 (1065)	88.1 (40)

MUELLER® Shur Stop™ Unit 68 PE Line Stopping System

Equipment, Parts and Dimensions

5. Cleaning/Inspection Machine

This device is used to allow cleaning of the pipe in which the stopper will be working. It also allows inspection of the fittings internal threads and cleaning if necessary before installing completion plug.

DIMENSIONS – Inches (mm)

L	W	H	WT – lbs (Kg)
12.51 (318)	12.44 (316)	31.85 (809)	11.4 (5.2)

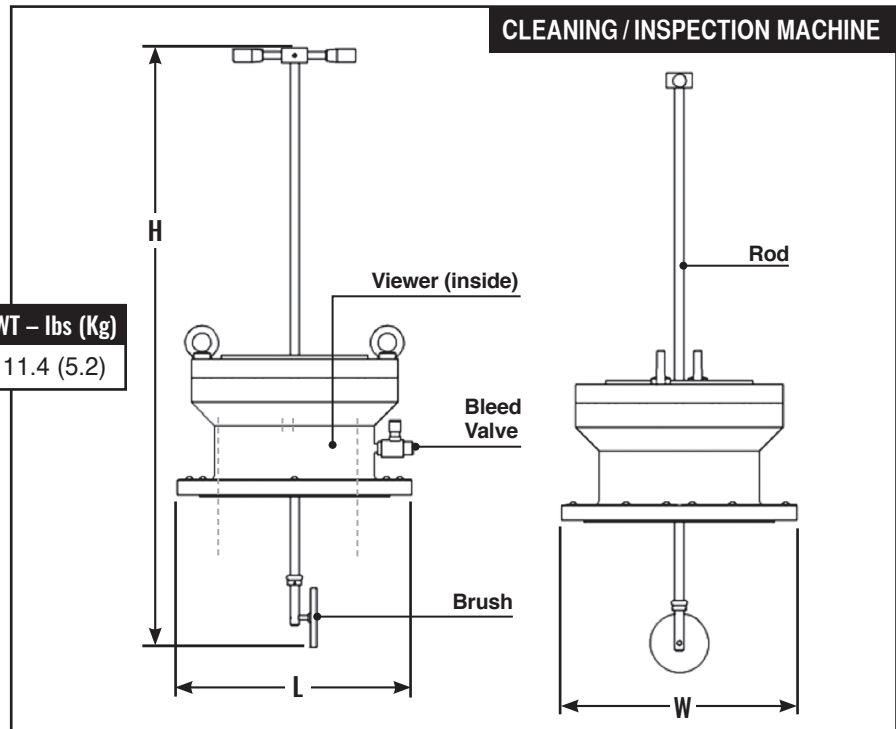

6. Drilling/Completion Machine

The Drilling Machine allows tapping operations through Shur-Stop 6" and 8" PE fittings. Specially designed cutters recover virtually all shavings and are equipped with pilot bit for coupon retention.

DIMENSIONS – Inches (mm)

L	ØW	H	WT – lbs (Kg)
12.44 (316)	12.44 (316)	66.53 (1690)	143.3 (65)

PE PIPE	HOLE Ø
6"	4.88 (124)
8"	6.88 (175)

SCOPE OF MACHINE

MACHINE	M.O.P (psi)	AMBIENT TEMP. (°F)	PIPE MATERIAL
Standard	125	-4/+122	Polyethylene

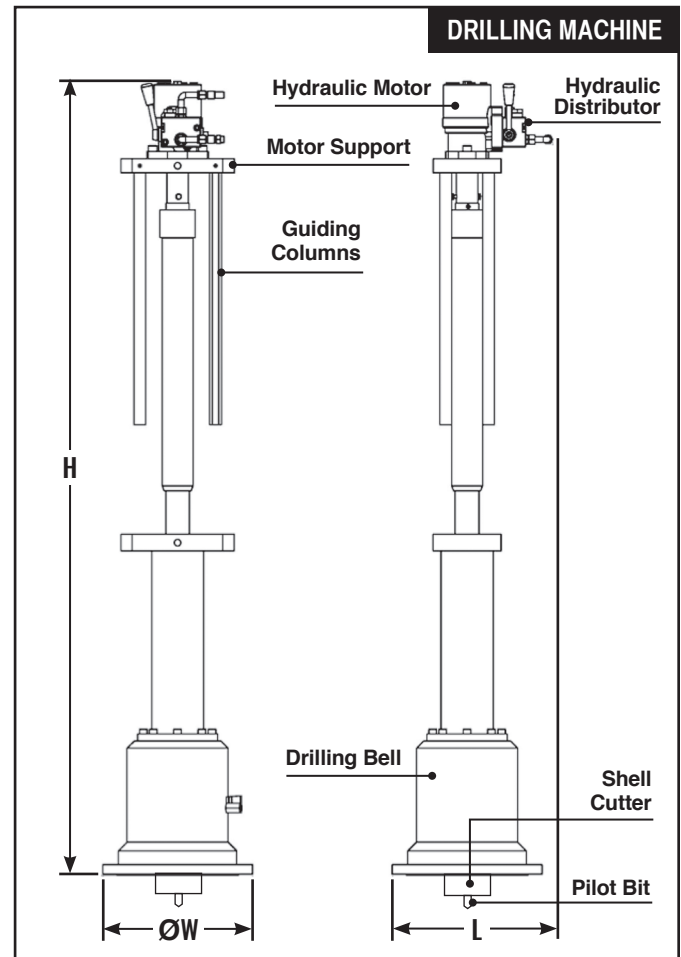

MUELLER® Shur Stop™ Unit 68 PE Line Stopping System

Operating Instructions

MACHINE USE

It is recommended to read and fully understand the recommended fitting installation guide outlined in Form #14960 before continuing.

ASSEMBLY AND USE

1. Position the electrofusion fitting on the pipe. Remove the completion plug O-rings and thread completion plug into fitting (A.).

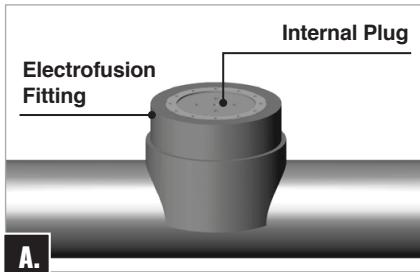

2. Position the Centering Clamp over the fitting with the lower plate open (B.) centering the pin on the central hole of the completion plug (B1.) and close the lower plate (B2.).

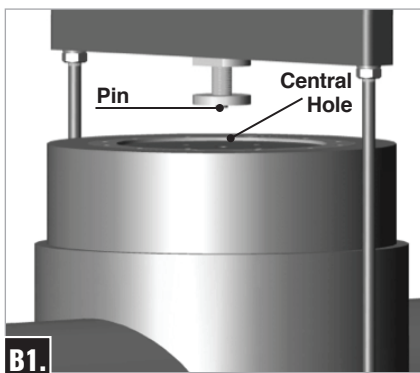
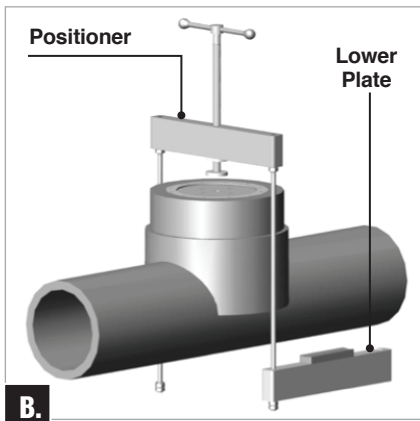

3. Align the pipe holder to the axis of the pipe (C.).

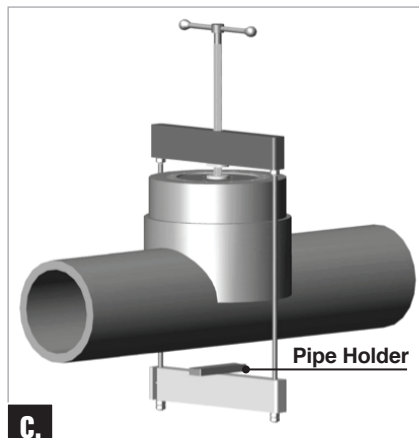

4. At this point rotate the screw of the centering clamp until the pipe holder is in contact with the pipe (D. & D1.).

⚠ CAUTION: The best compression is one where it is impossible to insert a 3mm metal feeler gauge between the fitting and the pipe. The proper recommended procedure is contained in the recommended fitting installation guide outlined in Form #14960.

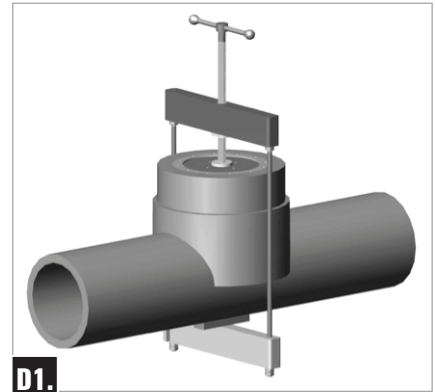
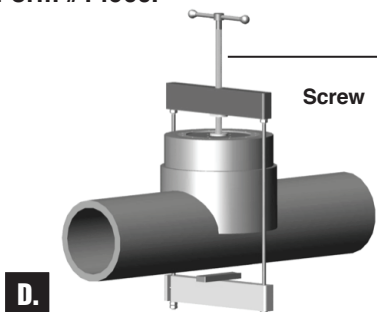

5. Perform the electrofusion referring to the technical data shown on page 3 and fitting barcode.

6. Allow sufficient time for cooling.

7. Turn the screw of the centering clamp counter-clockwise (E.).

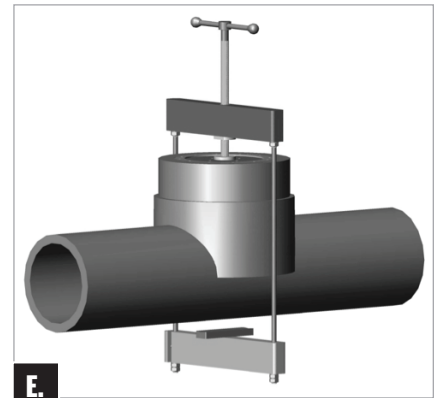

8. Turn the lower plate and remove the centering clamp (F. & F1.).

9. Unscrew the completion plug, thoroughly clean the seat and insert the sealing O-ring lubricating it with PURITY-FG Spray or equivalent.

10. Install the appropriate vent / purge fittings as required by company practice (G. & G1).

11. Allow sufficient time for cooling.

12. Prepare the slide gate valve with the lower ring of suitable diameter and attach to the electrofusion fitting (H.).

MUELLER® Shur Stop™ Unit 68 PE Line Stopping System

Operating Instructions

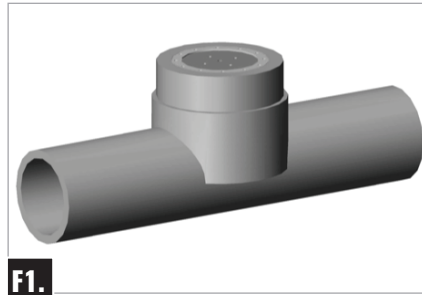

Preparation of Drilling Machine

1. Remove the machine body from the metal box.
2. Attach the pilot bit to the shell cutter arbor (**A.** & **A1.**).

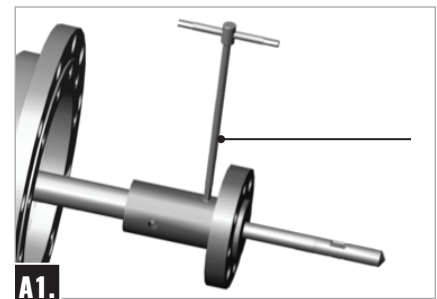
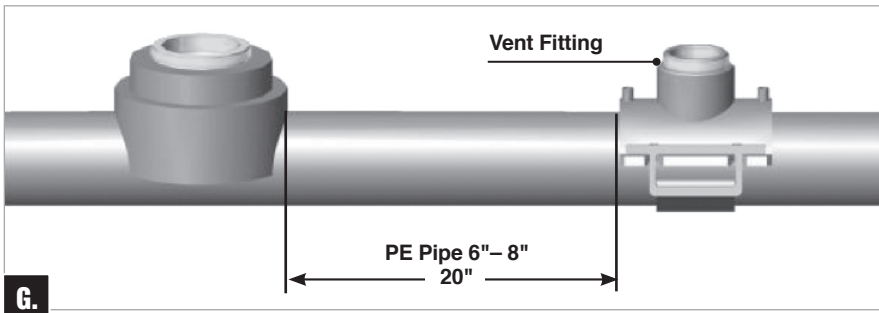
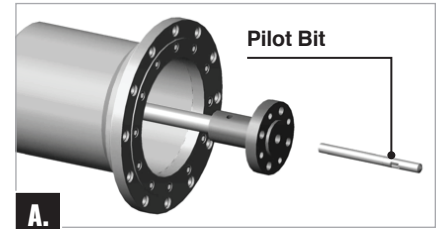

3. Attach shell cutter to arbor (**B.**).
4. Retract boring bar until shell cutter is fully inside machine housing.

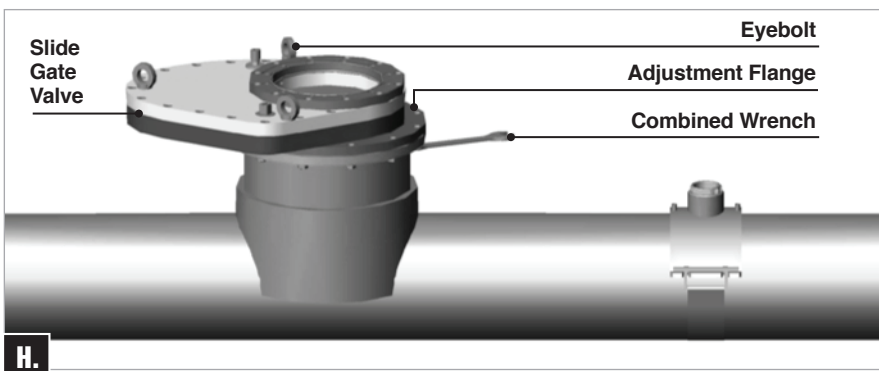
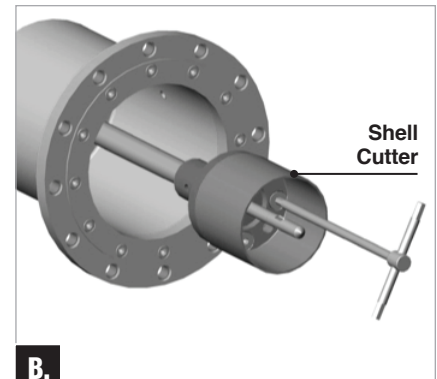
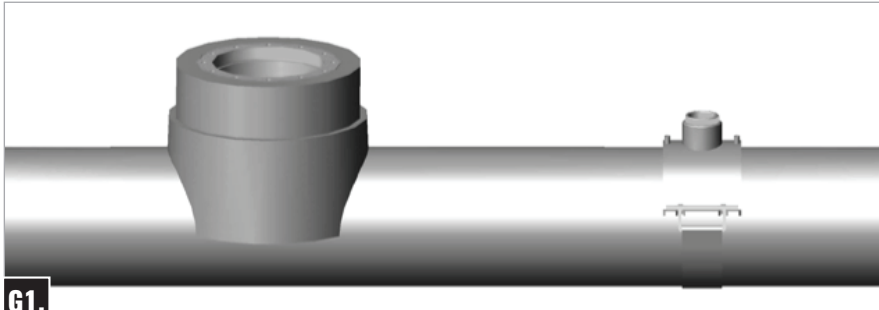

MUELLER® Shur Stop™ Unit 68 PE Line Stopping System

Operating Instructions

5. Lift and position the drilling machine onto the slide gate valve in the open position. Tighten the bolts in a criss-cross pattern.

Then turn the feed tube **clockwise** to lower the shell cutter until the pilot bit comes in contact with the pipe (**C.**).



⚠ CAUTION: After each opening and closing of the valve, remove the operating wrench to prevent accidental movement.

6. Turn the feed tube a quarter turn **counter-clockwise** to avoid jamming when drilling begins.

7. Position the motor support, onto the boring bar operating square. Ensure guide columns are lined up with housings (**D.**).

NOTE: There is an opening at the very top of the shaft. This is to allow the insertion of a pin, which ensures that the motor support bushing does not slide out (**E.**).

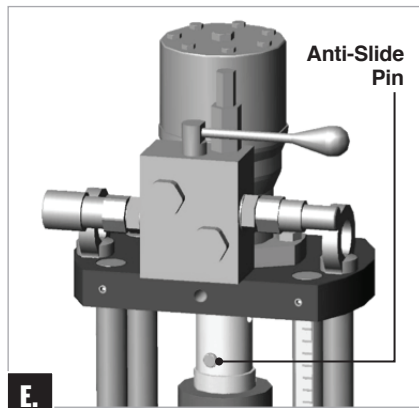
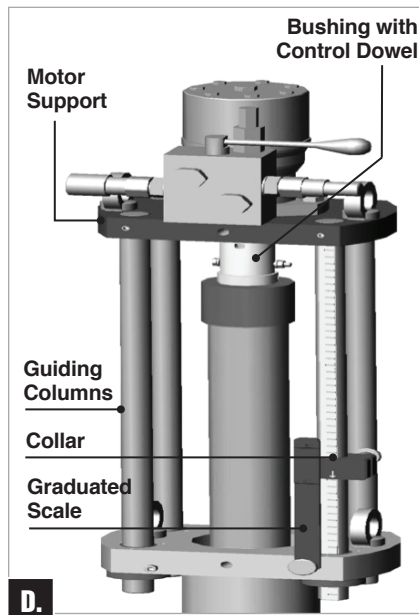

8. Connect the hoses coming from the hydraulic control unit to the quick couplings of the hydraulic operator ensuring the lever is in the neutral position (**F.**).

9. Start the hydraulic control unit.

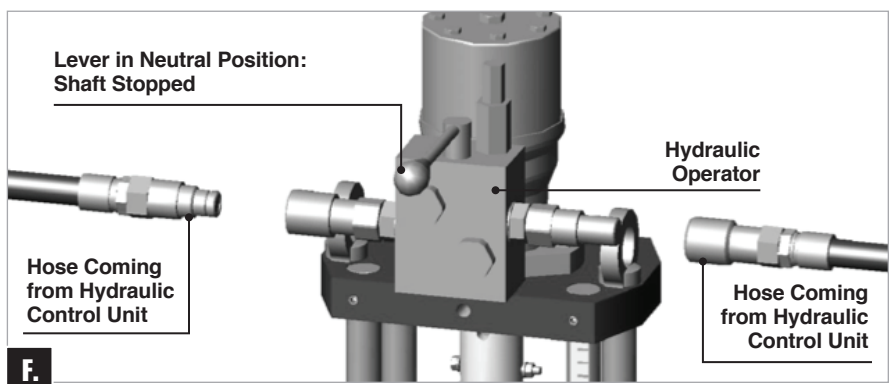

10. Turn the hydraulic distributor lever **clockwise** (**G.**).

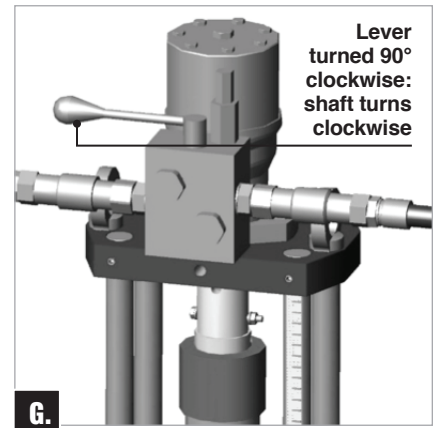

11. Turn the feed screw **clockwise** to begin drilling.

12. When the shell cutter makes contact with the pipe, turn off hydraulic operator and stop drilling.

13. Loosen the knob on the graduated scale.

14. Turn the graduated scale 90° **clockwise**.

15. Then turn the knob on the graduated scale until it is tight (**H.**)

16. Loosen the collar using the knob.

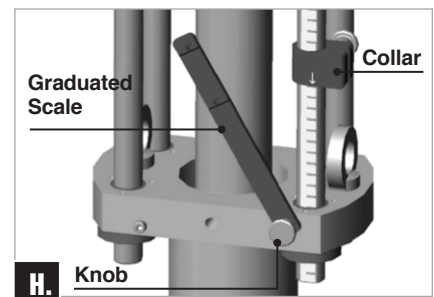

MUELLER® Shur Stop™ Unit 68 PE Line Stopping System

Operating Instructions

17. Move the collar down to bring the lower part (indicated by the tip of the arrow) in correspondence to the line below the diameter of the pipe on which the operation is being carried out (L).

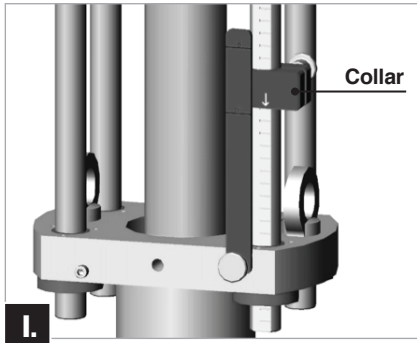

18. Loosen the knob on the graduated scale, turn the graduated scale 90° counter-clockwise and then tighten the knob (J).

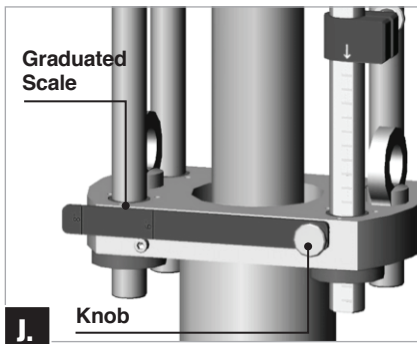

19. Turn on hydraulic power and begin drilling until the pipe coupon detaches. The location of the collar indicates the farthest travel the machine can be operated safely without drilling too far.

20. Return the hydraulic operator lever to the neutral position (K.)

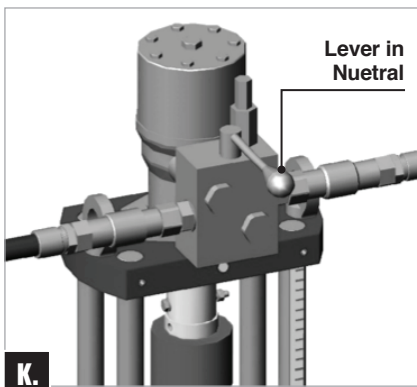

21. Turn off the hydraulic power and the hydraulic control unit.

22. Turn the feed screw counter-clockwise until the shell cutter is inside of the drilling bell.

23. Close the slide gate valve.

24. Attach relief piping (L).

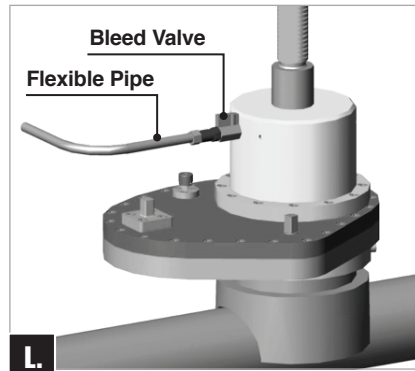

25. Purge the residual pressure above the closed gate a suitable distance from possible sources of ignition.

26. Remove hoses from the hydraulic control unit and operator.

27. Remove the drilling machine.

28. Carry out the cleaning operation using the cleaning inspection machine equipped with nylon wire brush (M.).

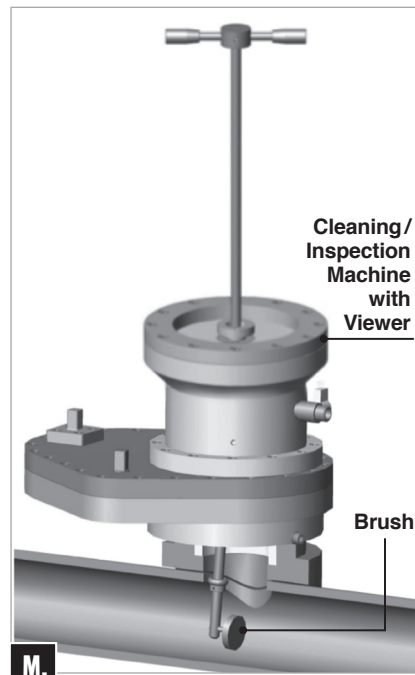

29. Proceed with stopping operation.

30. Check the operation of the expanding stopper. If the sealing ring does not expand evenly on the entire perimeter, it is necessary to lubricate the walls surrounding the ring with PURITY-FG Spray or equivalent (walls are compressed by two steel langes). Expand and retract the sealing ring a few times until the expansion is uniform. In the event that the stopper is not used for a long time, it is recommended to completely disassemble the stopper, replace the sealing ring and lubricate thoroughly. After reassembling the stopper, wipe the outer side of the ring that comes into contact with the inner side of the pipe.

31. Clean and lubricate the stopper bar and the sealing disk to provide smooth operation and to allow centering of the stopper during the expansion phase.

32. Position the stopping machine (N.) on the slide gate valve.

NOTE: There are 2 handles on the stopping machine. The longer one should always be on the upstream side.

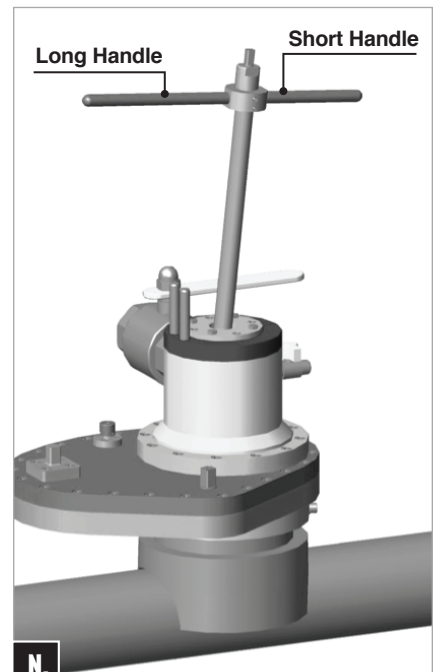

MUELLER® Shur Stop™ Unit 68 PE Line Stopping System

Operating Instructions

33. Perform the same operations on the second fitting and install the by-pass between the two machines.

Equalize the pressure (O.) of the first slide gate valve. For this operation rotate the knob that controls equalizing valve **counter-clockwise** until it stops.

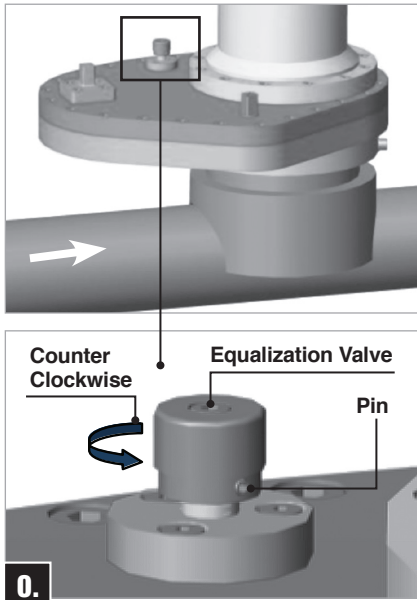

34. Open the slide gate valve.

35. Open the machine by-pass.

36. Open the machine by-pass located on the second stopping machine.

37. Purge the air in the by-pass through the drain valve located on the downstream stopping machine.

38. Open the second slide gate valve without acting on the internal pressure equalizer, as pressure is already equal above and below the gate.

39. Ensure the proper operation of the by-pass and check for leaks.

40. Leaving the safety ring loose, lower the stopper and position the long handle between the pins on the safety ring. If this is difficult, repeat previous step. If necessary, add stopping bar weights to top of stopping machine in order to assist lower stopper into pipe. Take care to ensure the plug is at a 90° position with respect to the pipe axis. Once the hole has been passed, place the plug in the downstream direction.

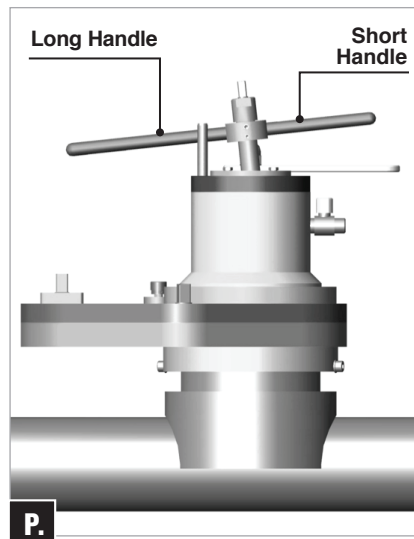

⚠ CAUTION: The plug should never be inserted and expanded on the upstream side.

41. Turn the ratchet handle **clockwise** and gradually expand the sealing ring of the stopper. During this operation slide the rod from top to bottom and vice versa to properly position the stopper in the pipe (P.).

42. Expand the sealing ring to obtain a positive shut-off. DO NOT over-tighten.

⚠ CAUTION: The torque applied to the ratchet spanner should not exceed 48 ft-lb for the 6" plug.

The torque applied to the ratchet spanner should not exceed 52 ft-lb for the 8" plug.

43. If leakage occurs between the stopper bar and the sealing disk gradually tighten the Allen screws.

44. Repeat the same operations on the second stopper machine.

45. Purge remaining gas through No. 1 and No. 2 (Q.).

46. Tighten the safety ring.

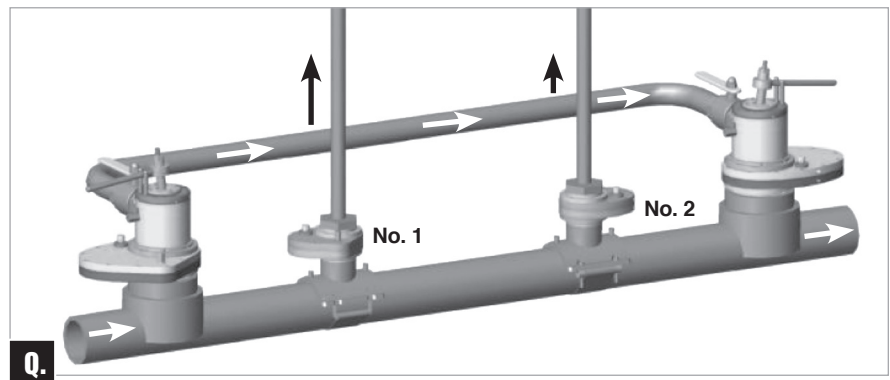

MUELLER® Shur Stop™ Unit 68 PE Line Stopping System

Operating Instructions

47. Make the repairs.

48. Before decompressing the the sealing ring, it is necessary to equalize the pressure upstream and downstream of the same stopper.

When only gas comes out of the vent No. 2, close the respective gate valve letting the gas equalize pressure. It is now possible to test the new connections (**R.**).

49. Decompress the sealing ring of the stopper by operating **counter-clockwise** on the ratchet handle until a hard stop and retract the stopper inside the stopping machine.

50. Repeat the same operations on the second stopping machine (**S.**).

51. Close the related slide gate valves (**T.**).

52. Bleed the gas contained in the by-pass at a suitable distance from possible sources of ignition (**U.**).

53. Remove the by-pass and the stopping machines (**V.**).

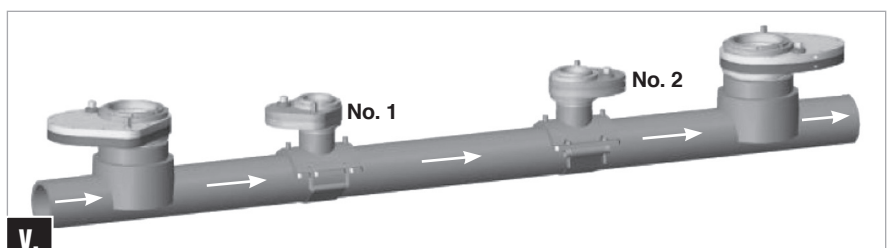
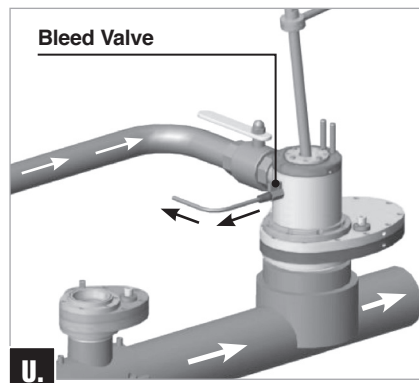
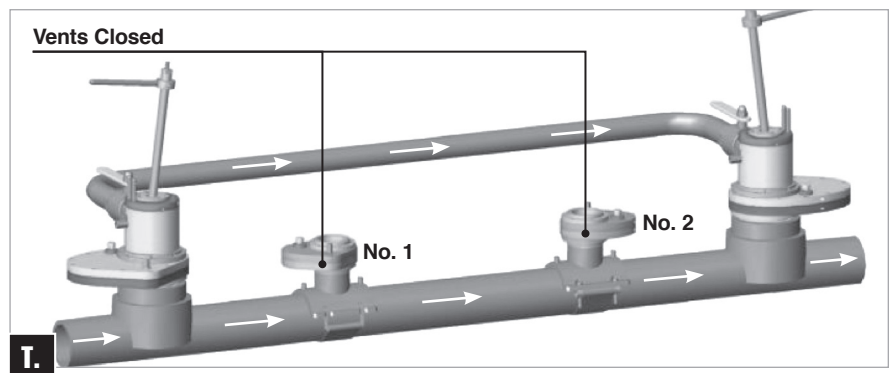
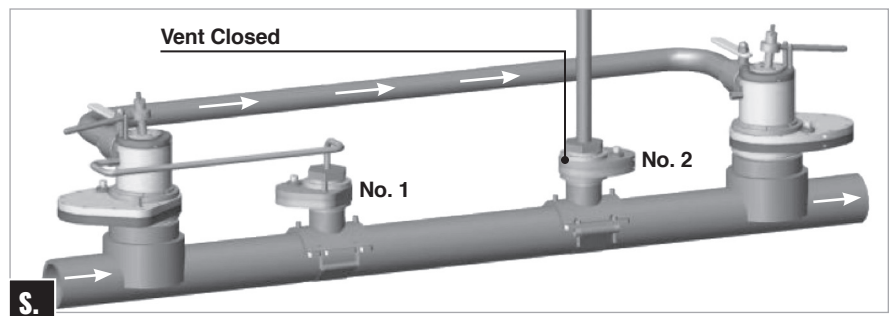
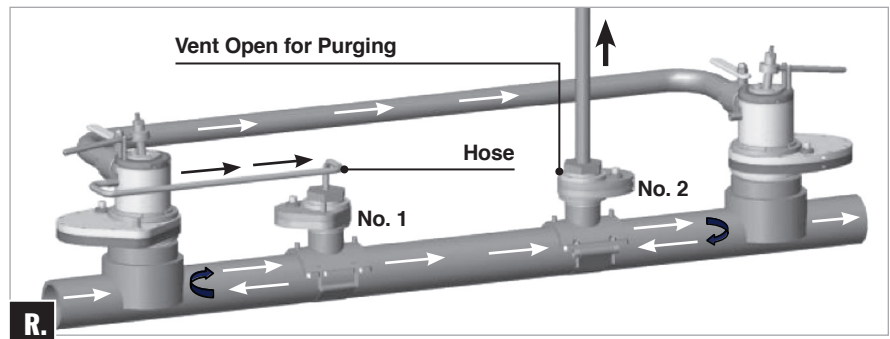

MUELLER® Shur Stop™ Unit 68 PE Line Stopping System

Operating Instructions

Preparation of Drilling Machine To Insert Completion Plug

1. Attach completion plug holder support to the drilling machine shaft (A. & A1.).

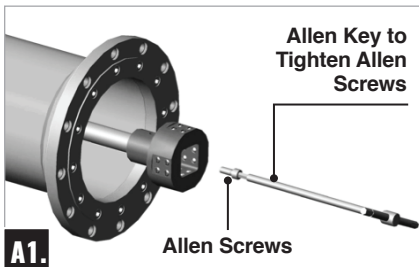
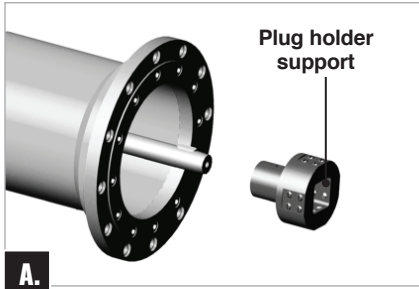

2. For the 6", screw the inserting tool onto the completion plug by aligning two of the four holes. Tighten the locking screws but do not tighten completely, leaving some minimal play between the two parts (B.).

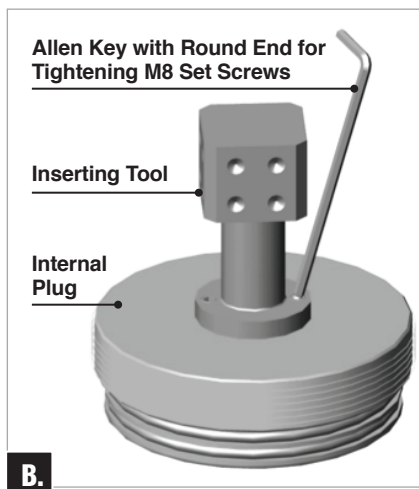

3. For 8", place the plug holder flange on the completion plug and attach it with the provided screws (C.).

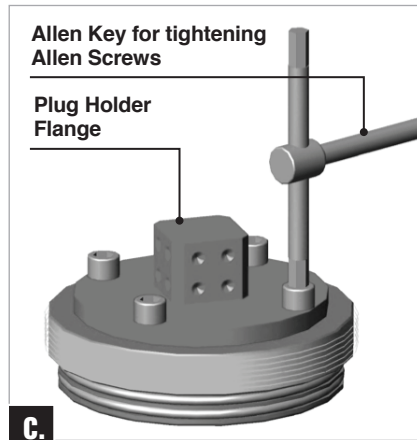

4. Attach the inserting tool and plug onto the plug holder support and tighten the spring detents (D.).

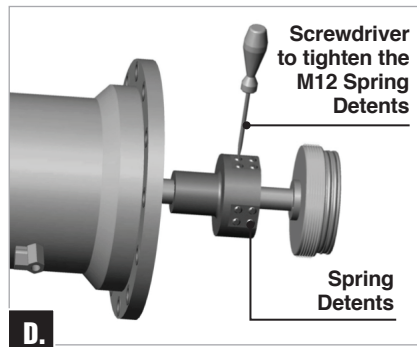

5. Lubricate the O-ring of the internal plug with PURITY-FG Spray or equivalent and retract the plug into the machine adapter.

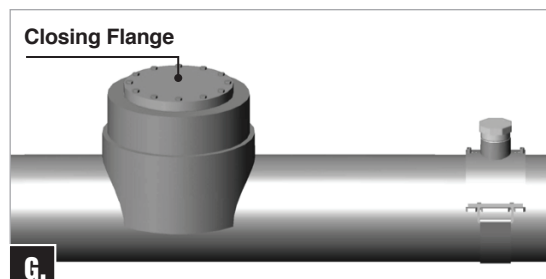
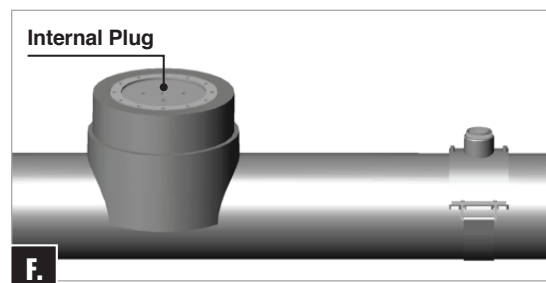

6. Assemble the completion machine on the slide gate valve, open the equalization valve and then open the slide gate valve.

7. Turn the feed screw **clockwise** and move the completion plug towards the fitting.

8. Install the ratchet handle (E.).

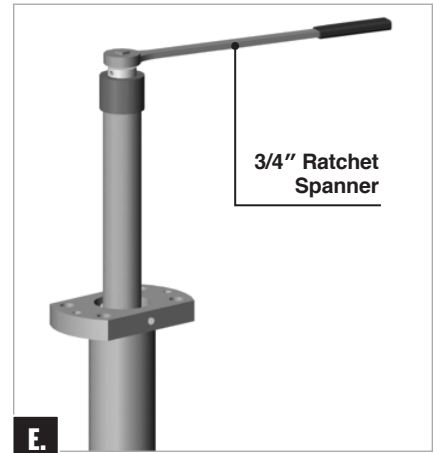

9. Fully tighten the completion plug, taking care to **SIMULTANEOUSLY** turn both the ratchet and the lead screw **clockwise**.

10. Bleed any residual pressure off using the bleed valve (see point 28 on page 9) and check the completion plug for leaks.

11. Remove the ratchet and turn the feed screw of the machine **counter-clockwise** until the shaft is released from the plug holder support.

12. Remove the completion machine, the slide gate valve and the plug holder support (F.).

13. Install the completion cap (G.).

Preparation of Drilling Machine to Remove the Completion Plug (6-8")

COMPLETION PLUG EXTRACTION INSTRUCTIONS

1. Attach extraction bar adapter onto the completion/ extraction bar by aligning the adapter with keyway on the machine. Secure the adapter by tightening allen screw to the end of completion/ extraction bar. **(A & A1).**

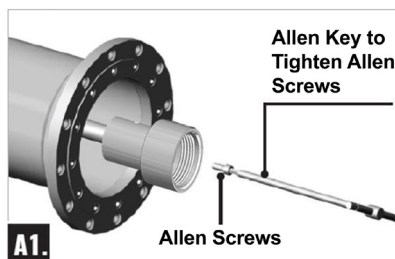
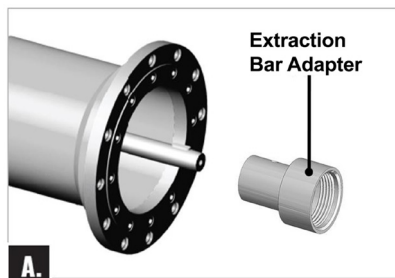

2. Attach the extraction tool onto the completion plug.
 - a. For the 6" fitting, thread the extraction tool fully onto the completion plug aligning two of the four holes. It may be necessary to unthread the tool slightly to align holes. Tighten the locking set screws securely with allen key. **(B.)**
 - b. For the 8" fitting, place the extraction tool onto the completion plug. Secure to the plug by tightening with four provided allen screws. **(C.)**

Fully retract the completion/extraction bar and adapter into the machine housing.

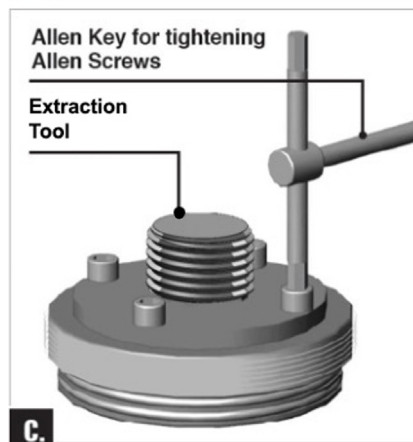

Preparation of Drilling Machine to Remove the Completion Plug (6-8")

COMPLETION PLUG EXTRACTION INSTRUCTIONS

3. Attach Unit 68 gate valve to the fitting using appropriate adapter.
4. Attach the completion machine onto the Unit 68 gate valve. Equalize the pressure above the completion plug from an external source through the machine relief valve.
5. Advance completion/extraction bar downward by rotating feed tube clockwise until adapter contacts the top of the extraction tool.
6. Install the ratchet handle on the top operating nut of the extraction bar. Thread the extraction bar adapter onto the extraction tool connected to the completion plug. This is performed by turning the ratchet handle counterclockwise. Be sure to turn the feed tube clockwise to provide constant downward pressure. Continue until the extraction tool adapter is completely threaded onto the extraction tool. Ratchet handle will stop rotating when fully engaged.
7. Once the extraction tool is completely engaged, relieve tension by removing the gap between the thrust bearing and thrust collar. Unthread the completion plug by turning counterclockwise with the ratchet handle and feed tube. Continue until the completion plug is extracted. **(E)**



8. Remove the ratchet handle and continue turning the feed tube counterclockwise until the extraction bar is in its rearmost position.
9. Close the slide gate valve and purge pressure in the machine through the relief valve.
10. Remove the completion machine from the gate valve and disconnect the extraction tool and plug from extraction bar.

*Please note the extraction tool and extraction bar adapter have left-handed threads which will require turning clockwise to release.

MUELLER® Shur Stop™ Unit 68 PE Line Stopping System

Troubleshooting / Storage

TROUBLESHOOTING

PROBLEM	CAUSE	SOLUTION
Drilling time too long	Worn cutter	Replace the cutter.
Gas leakage between the drilling shaft and the screw	Worn O-rings	Replace the O-rings.
Inadequate sealing of the stopper	No lubrication performed on the oblique walls of the sealing ring	With PURITY-FG Spray or equivalent, lubricate the angled walls of the sealing ring expanding and retracting it completely.
	No lubrication performed on the sealing disk of the plug bell	Lubricate the sealing disk with PURITY-FG Spray or equivalent.
	Presence of residue on the bottom of the pipe	Clean again using the inspection / cleaning machine.
Inadequate sealing of the sealing disk	Insufficient tightening of the screws of the flange that compress the sealing disk	Tighten the screws slightly.
Inadequate sealing of the valve	Equalization valve not closed	Close the equalization valve.
	Residue on the sealing O-ring	Before the next use, replace the O-rings.

STORAGE

In case of long periods of inactivity, the equipment must be stored taking suitable precautions for the place it is stored in and the duration of the storage:

- Store the equipment in a closed place.
- Protect the equipment for humidity and extreme changes in the temperature.

- Prevent corrosive substance coming into contact with the equipment.



Gas (North America)
1.800.798.3131
www.muellergas.com
moreinfo@muellercompany.com