

MUELLER® GAS

Shur Stop™ PE Line Stopping System

4" – 6"

SDR 11 - 11.5 - 13.5

Form 13262 - Rev 10/24

⚠ WARNING:

1. Read and follow instructions carefully. Proper training and periodic review regarding the use of this equipment is essential to prevent possible serious injury and/or property damage. The instructions contained herein were developed for using this equipment on fittings of Mueller manufacturer only, and may not be applicable for any other use.
2. Do not exceed the pressure ratings of any components or equipment. Exceeding the rated pressure may result in serious injury and/or property damage.
3. Safety goggles and other appropriate protective gear should be used. Failure to do so could result in serious injury.
4. Pressure test, check for and repair leaks in all fittings and components each time one is installed or any joint or connection is broken. Failure to find and repair a leak from any source in the fittings, by-pass lines or equipment could result in an explosion and subsequent serious injury and/or property damage.
5. MUELLER® Drilling Machines and Equipment have been carefully designed and engineered to work together as a unit. The use of equipment manufactured by someone other than Mueller Co. may cause excessive wear or a malfunction of the MUELLER machines.

TABLE OF CONTENTS	PAGE
General Information	2
Equipment, Parts and Dimensions	3-5
Operating Instructions	6-11
Completion Plug Extraction Instructions	12-14
Maintenance and Part Replacement	15-17
Troubleshooting and Storage	18



Customer Service Center
Decatur, Illinois
800.798.3131
www.muellergas.com
moreinfo@muellercompany.com

All warranties, expressed or implied, for Mueller Drilling Machines are rendered null and void if the machines are used with shell cutters or equipment manufactured by someone other than Mueller Co.

MUELLER® Shur Stop™ PE Line Stopping System

General Information and Equipment

OVERVIEW

The Shur Stop PE stopping system allows NO BLO stopping operations on 4" and 6" (SDR 11 - 11.5 - 13.5) polyethylene pipes operated up to a maximum operating pressure of 125psig (Actual MAOP will be dependent on the operating pressure of the PE pipe).

This manual describes all operations including drilling, stopping and completion plug insertion.

Basic Equipment Required

1. Electrofusion Fitting
2. Centering Clamp
3. Slide Gate Valve
4. Stopping Unit
5. Cleaning/Inspection Viewer
6. Combination Drilling/Completion Machine

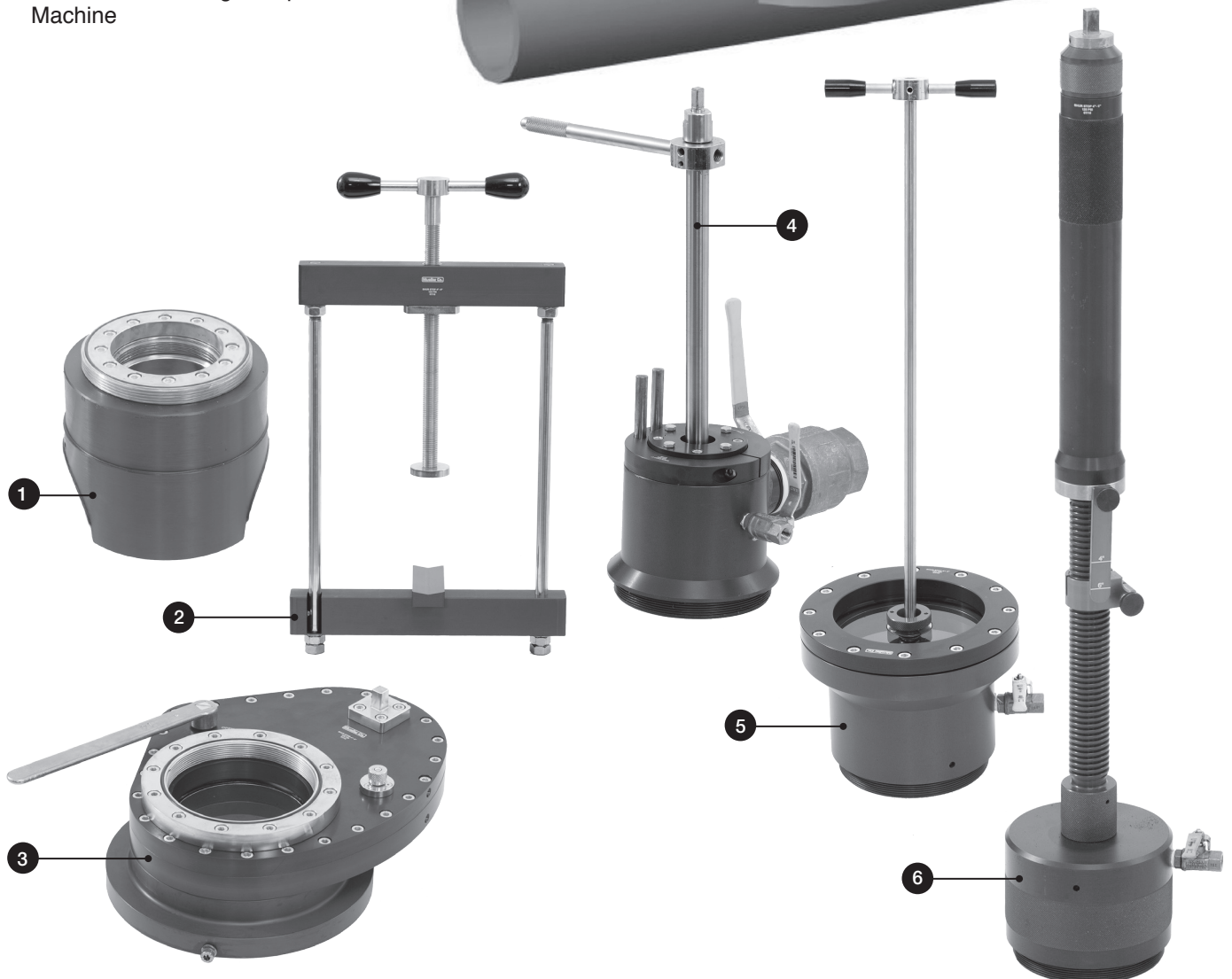
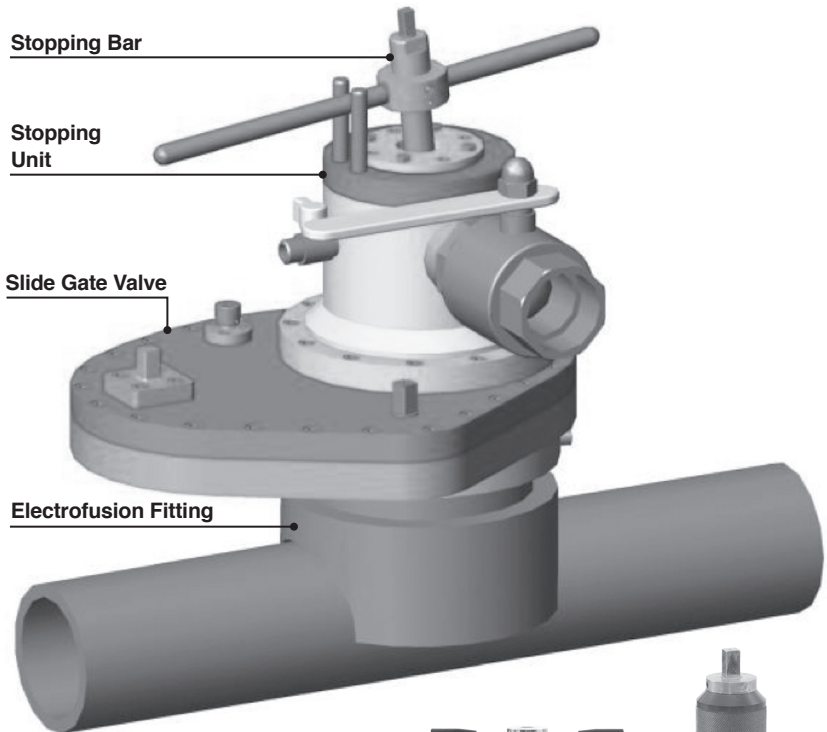

MUELLER® Shur Stop™ PE Line Stopping System

Equipment, Parts and Dimensions

EQUIPMENT

1. Electrofusion Fitting

Each Fitting is composed of:

- Electrofusion base with metal bushing;
- Internal plug with O-ring;
- Completion Cap (for 4") or Completion Flange (for 6"), both with O-ring seal.

NOTE: These fittings are compatible with any universal processor available on the market equipped with a barcode pen/scanner.

Electrical Parameters

- Frequency of power supply current 50 Hz
- Output voltage 8V - 48V

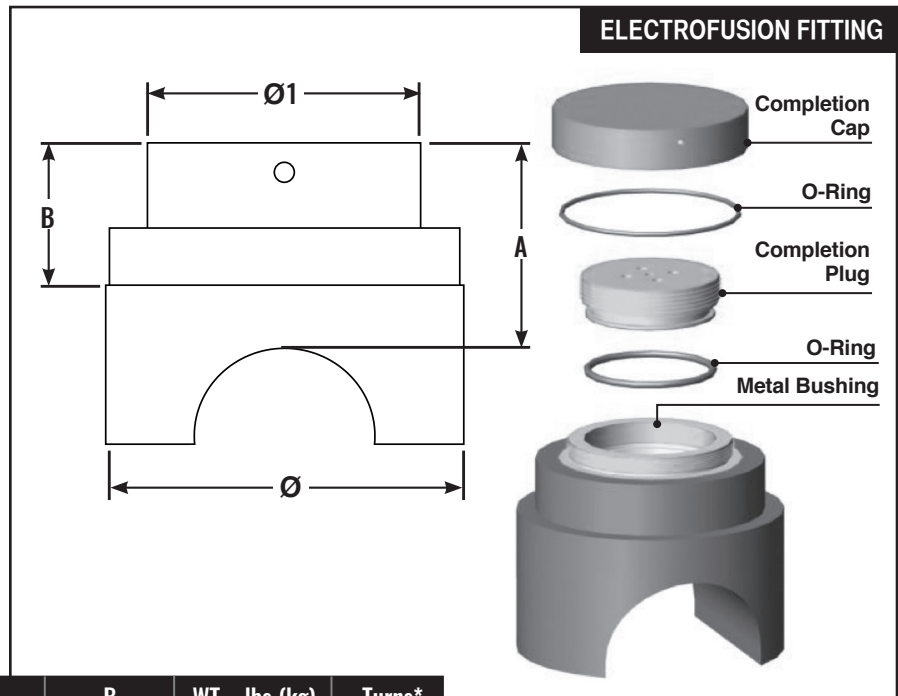

PE PIPE	Ø	Ø1	A	B	WT – lbs (kg)	Turns*
4"	7.87 (200)	5.32 (135)	3.94 (100)	2.68 (68)	16.76 (7.6)	3 ¹ / ₄ ± 1 ¹ / ₄
6"	10.24 (260)	7.64 (194)	5.59 (142)	4.13 (105)	56.88 (25.8)	3 ³ / ₄ ± 1 ¹ / ₄

*Number of revolutions to install Completion Plug

2. Centering Clamp for Electrofusion Fitting

The Centering Clamp is used to properly align the Electrofusion Fittings to the pipe during the fusion process. It is designed to evenly distribute the clamping force applied by the operator.

DIMENSIONS – Inches (mm)

L	W	H	WT – lbs (Kg)
13.82 (351)	1.97 (50)	31.81 (808)	16.09 (7.3)

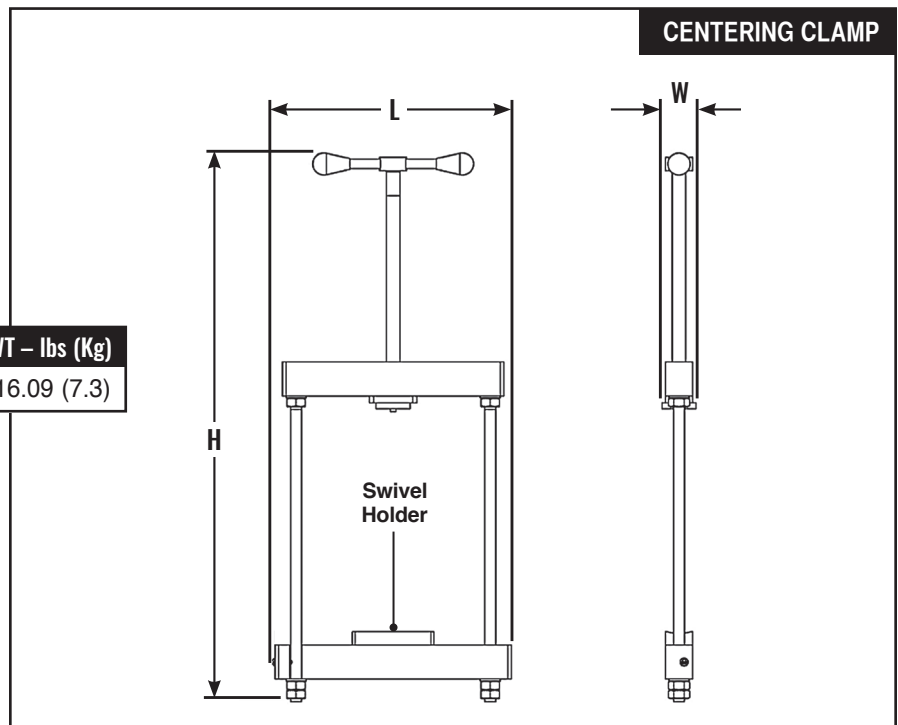

MUELLER® Shur Stop™ PE Line Stopping System

Equipment, Parts and Dimensions

3. Slide Gate Valve

The Slide Gate Valve has a design which allows a 35% weight reduction compared to similar round slide valves with the same bore size. It consists of a sliding gate housed between two flat bodies; pressure is held firmly by two O-rings, one above and one underneath. The valve is fitted with an internal pressure equalizer which allows easy opening when pressure varies between the upper and lower parts of the valve. To open and close the valve, turn the operating square approximately a quarter turn.

DIMENSIONS – Inches (mm)

PE PIPE	L	W	H	A	WT – lbs (Kg)
4"	15.04 (382)	12.21 (310)	4.55 (115)	5.51 (140)	31.75 (14.4)
6"	16.02 (407)	12.32 (313)	5.37 (136)	5.51 (140)	33.95 (15.3)

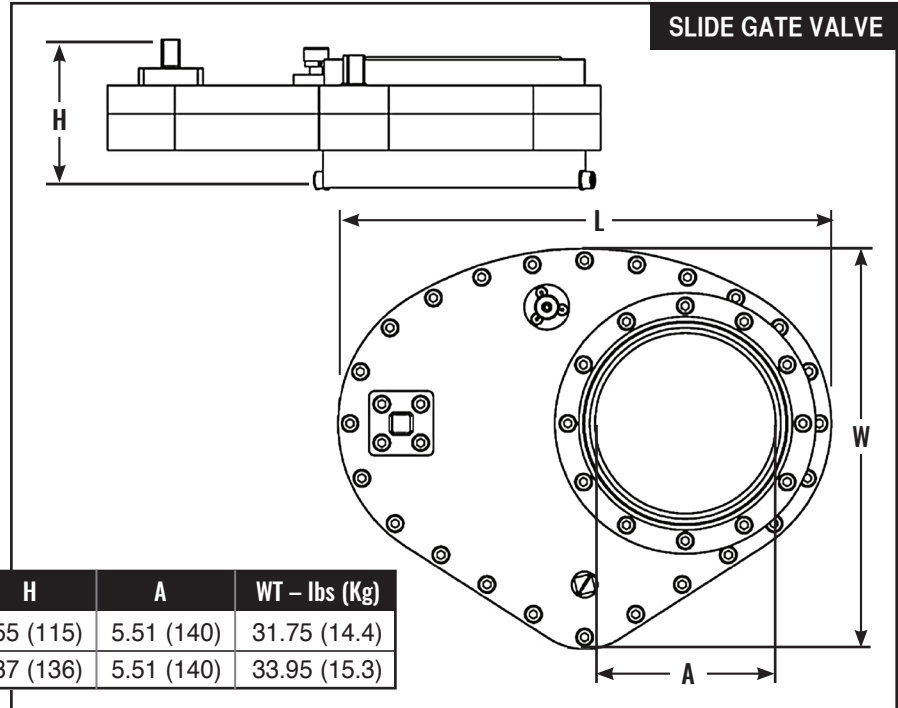

⚠ CAUTION: Never leave the valve with the gate in the closed position when not in use. In the event that the gate is stuck, loosen the screws holding the two valve bodies, bring the gate to the open position and retighten the screws.

4. Stopping Unit

The Stopping Unit is composed of:

- A stopping unit with bypass valve, bleed valve and available gas source (equalizer);
- An expanding stopper consisting of two flanges.

On the upper part of the stopping bar there is an operating square that when turned (**clockwise**) the two flanges compress resulting in the expansion of the sealing ring.

The result is full contact between the sealing ring and the inner wall of the pipe, ensuring complete gas control. The affect is 100% stop off.

DIMENSIONS – Inches (mm)

PE PIPE	L	W	H	WT – lbs (Kg)
4"	15.20 (386)	11.38 (289)	19.33 (491)	22.05 (10.0)
6"	17.38 (441)	12.00 (305)	29.55 (750)	38.58 (17.5)

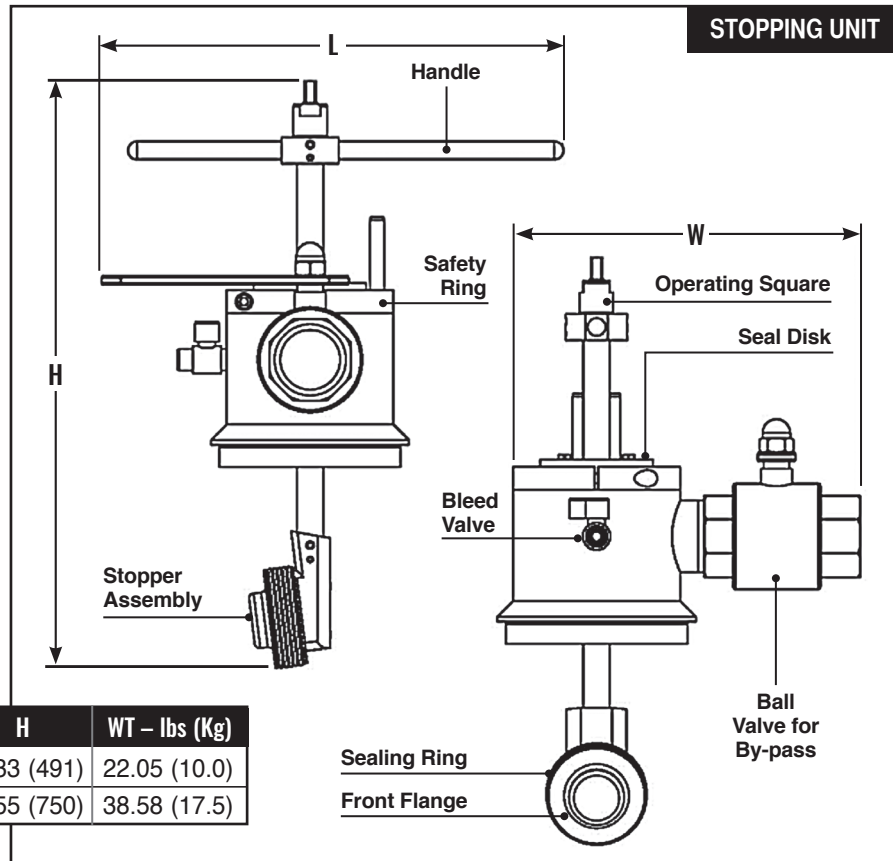

MUELLER® Shur Stop™ PE Line Stopping System

Equipment, Parts and Dimensions

5. Cleaning/Inspection Viewer

This device is used to allow cleaning of the pipe which the stopper will be working. It also allows inspection of the fittings internal threads and cleaning if necessary before installing completion plug.

DIMENSIONS – Inches (mm)

L	W	H	WT – lbs (Kg)
9.45 (240)	8.5 (216)	25.55 (649)	10.36 (4.78)

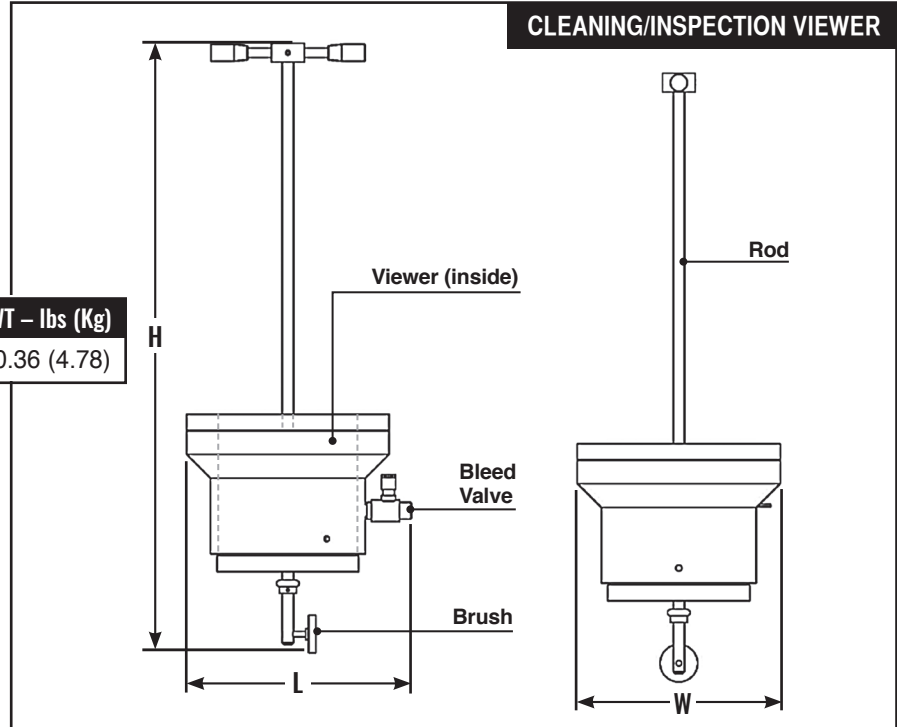

6. Drilling/Completion Machine

The Drilling Machine allows tapping operations through Shur-Stop 4" and 6" PE fittings. Specially designed cutters recover virtually all shavings and are equipped with pilot bit for coupon retention.

The Drilling Machine also acts as the Completion Machine by performing a quick exchange from the drilling bar to a completion bar.

DIMENSIONS – Inches (mm)

L	W	H	WT – lbs (Kg)
7.71 (196)	6.49 (165)	40.15 (1020)	17.63 (8)

PE PIPE	HOLE Ø
4"	3.38 (86)
6"	4.88 (124)

SCOPE OF MACHINE

MACHINE	FLUID M.O.P (psi)	AMBIENT TEMP. (°F)	PIPE MATERIAL
Standard	125	-4/+122	Polyethylene

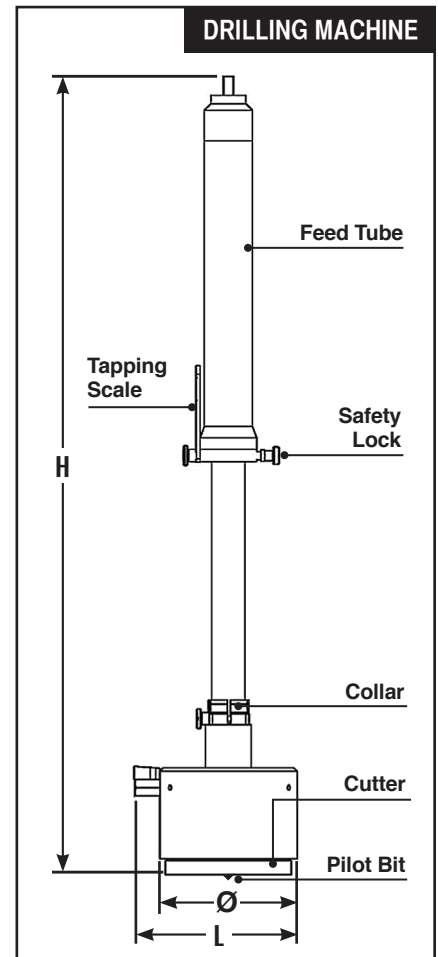

MUELLER® Shur Stop™ PE Line Stopping System

Operating Instructions

OPERATING INSTRUCTIONS

It is recommended to read and fully understand the recommended fitting installation guide outlined in Form # 14960 before continuing.

ASSEMBLY AND USE

1. Position the electrofusion fitting on the pipe. Remove the completion plug O-ring and thread completion plug into fitting (**A.**).

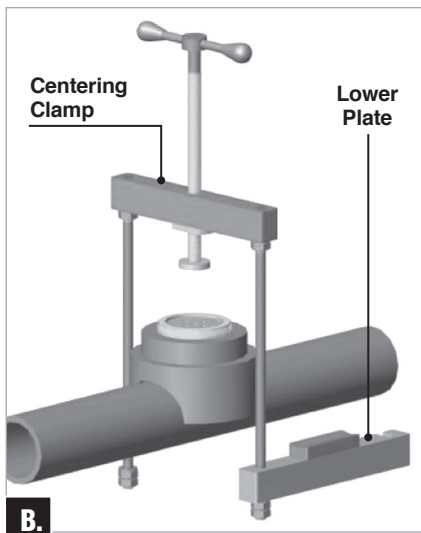
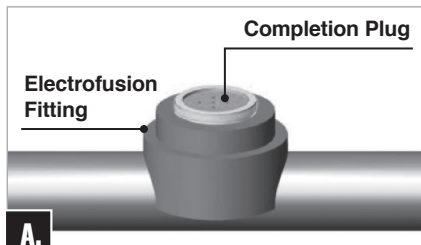

2. Position the Centering Clamp over the fitting with the lower plate open (**B.**), centering the pin on the central hole of the completion plug (**B1.**) and close the lower plate (**B2.**).

3. Align the pipe holder to the axis of the pipe (**C.**).

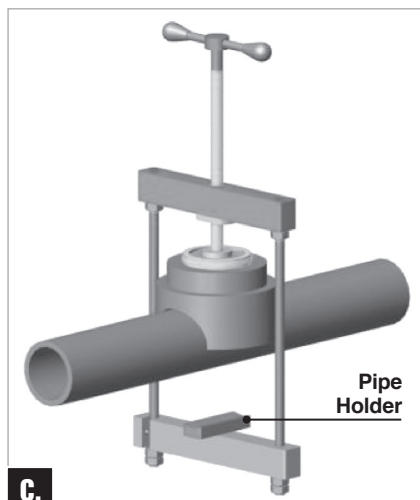
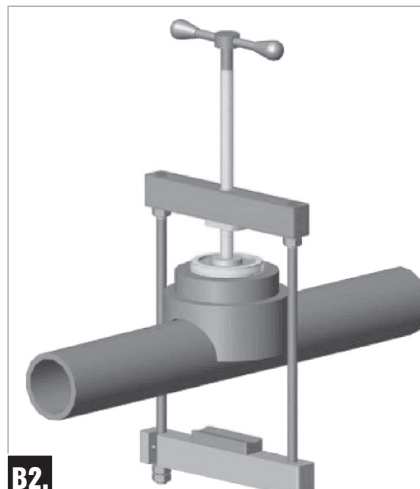
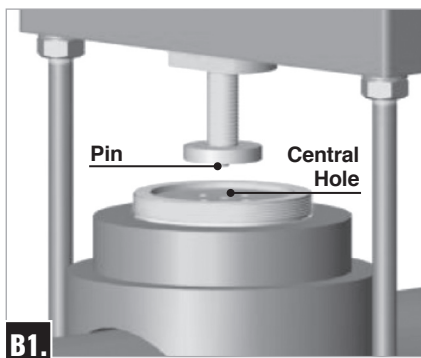

4. At this point rotate the screw of the centering clamp until the pipe holder is in contact with the pipe (**D.** & **D1.**).

⚠ CAUTION: The best compression is one where it is impossible to insert a .3mm metal feeler gauge between the fitting and the pipe. The proper recommended procedure is contained in the recommended fitting installation guide outlined in Form #14960.

5. Perform the electrofusion referring to the technical data shown on page 3.

6. Allow sufficient time for cooling.

7. Turn the screw of the centering clamp counter-clockwise (**E.**).

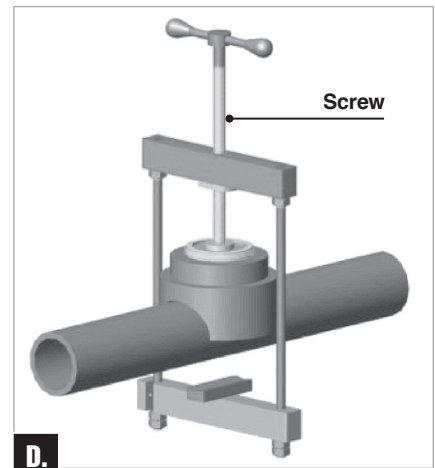

MUELLER® Shur Stop™ PE Line Stopping System

Operating Instructions

8. Turn the lower plate and remove the centering clamp (F. & F1.).

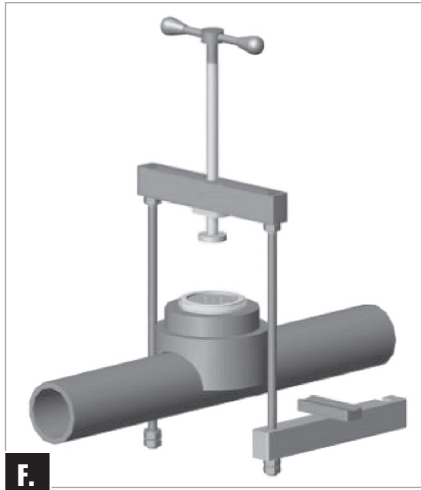

F.

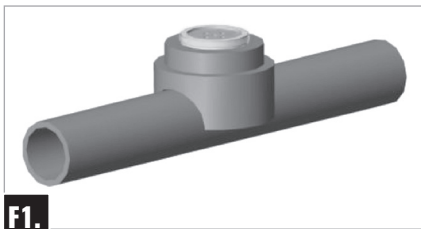

F1.

9. Unscrew the completion plug, thoroughly clean the seat and insert the sealing O-ring lubricating it with PURITY-FG Spray or equivalent.

10. Install the appropriate vent/purge fittings as required by company practice (G.).

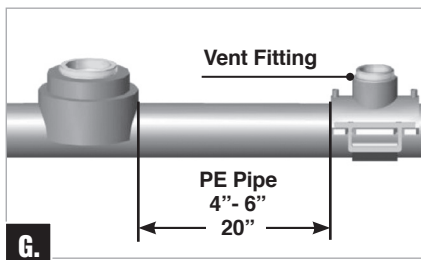

G.

11. Allow sufficient time for cooling.

NOTE: If the work is carried out on 6" pipe it is necessary to screw the threaded adapter to the electrofusion fitting (H.).

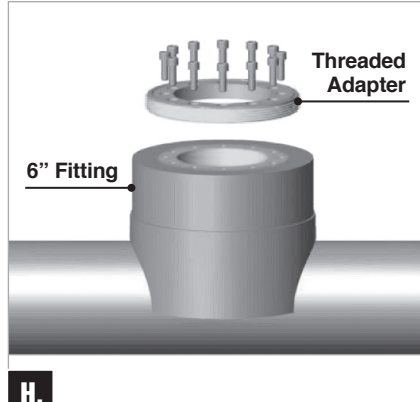

H.

12. Prepare the slide gate valve with the lower ring of suitable diameter and screw it on the electrofusion fitting.

13. Tighten the locking screws of the lower locking ring nut (I.).

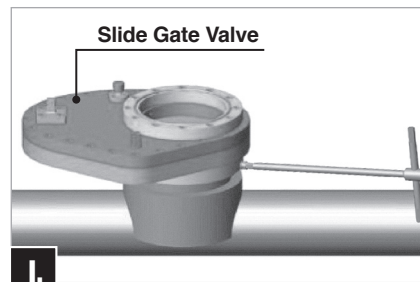

I.

PREPARATION OF DRILLING MACHINE

2. Extend the drilling shaft from end of machine adapter (A.).

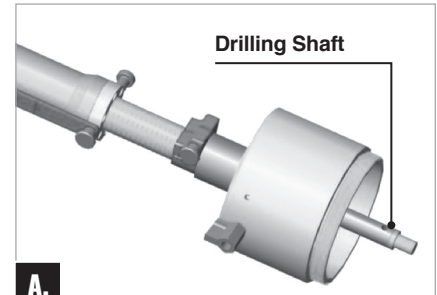

A.

3. Tighten the cutter and pilot bit to the drilling shaft by using 8mm pin punches (B.).

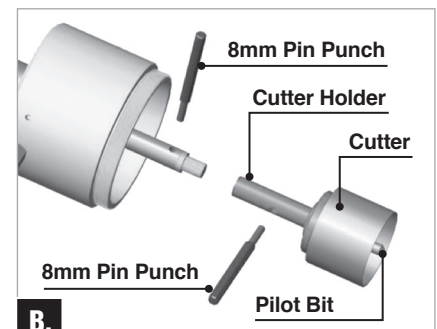

B.

4. By turning the feed tube **counter-clockwise**, retract the cutter into the machine adapter (C.).

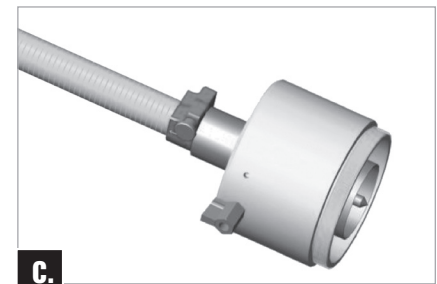

C.

MUELLER® Shur Stop™ PE Line Stopping System

Operating Instructions

5. Thread drilling machine onto the slide gate valve (**D.**).



6. Open the slide gate valve by turning the square operating nut **counter-clockwise** (**D1.**).

⚠ CAUTION: After each opening and closing of the valve, remove the operating wrench to prevent accidental movement.

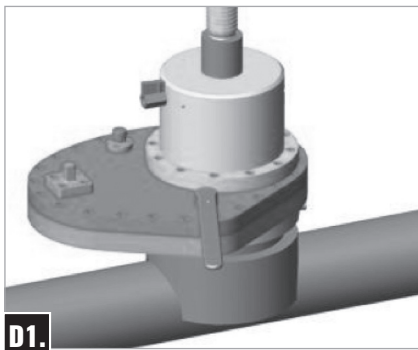

7. Turn the feed tube **clockwise** to lower the cutter until the pilot bit comes into contact with the pipe. Turning further compresses the

internal spring. This can be seen as the distance (approximately $\frac{1}{10}$ "") between the bearing holder bushing and the lock washer increases (**E.**). Turning **clockwise** increases the drilling pressure, turning **counter-clockwise** decreases the pressure.

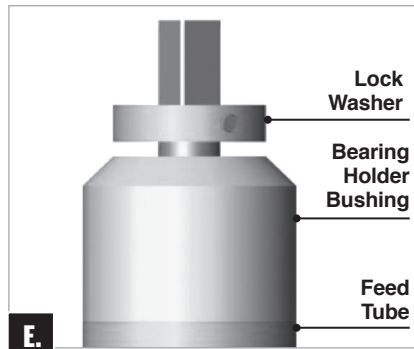

8. Now insert the ratchet handle on the operating nut and start drilling with the pilot bit by turning **clockwise** while turning feed tube **clockwise** (**F.**).

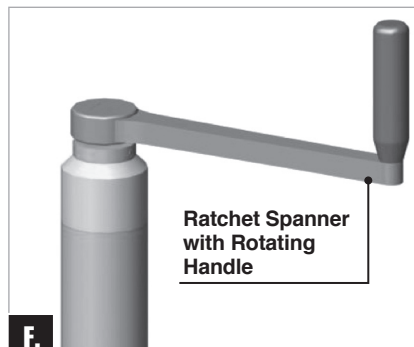

9. After the cutter contacts the pipe, stop the operation and totally remove pressure to the spring by turning the feed tube **counter-clockwise**.

10. Turn the knob of the graduated scale **counter-clockwise** a quarter turn (**G.**).

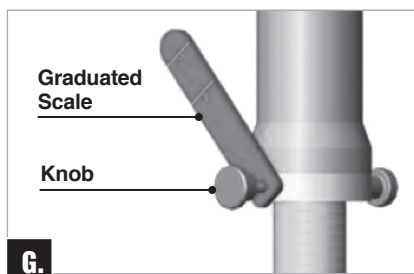

11. Turn the graduated scale 180°.

12. Loosen the collar using the knob.

13. Move the collar up to bring the upper part (indicated by the arrowhead) in correspondence to the line below the diameter of the pipe on which the operation is being carried out (**H.**).

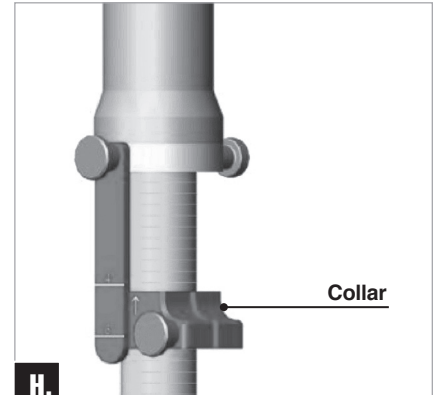

14. Move again the graduated scale 180° and tighten the related knob (**I.**).

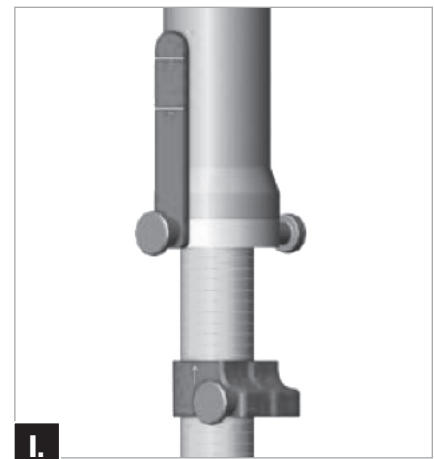

15. Restart the drilling operation proceeding until the coupon detaches from pipe. The presence of the collar provides maximum travel depth.

16. Retract the cutter in the machine adapter.

17. Close the slide gate valve.

18. Purge the residual pressure above the closed gate a suitable distance from possible sources of ignition.

MUELLER® Shur Stop™ PE Line Stopping System

Operating Instructions

19. Remove the pipe drilling machine.

20. Carry out the cleaning operation inside the pipe, using the cleaning/inspection viewer (K.) equipped with nylon wire brush (K1.).

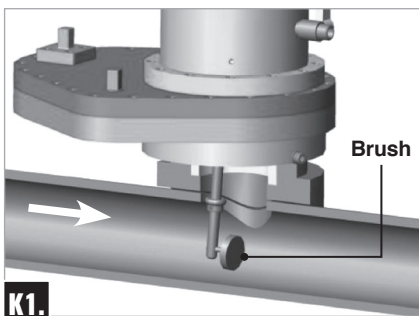

21. Proceed with stopping operation.

22. Check the operation of the expanding stopper. If the sealing ring does not expand evenly on the entire perimeter, it is necessary to lubricate the walls surrounding the ring with PURITY-FG Spray or equivalent (walls are compressed by two steel flanges). Expand and retract the sealing ring a few times until the expansion is uniform. In the event that the stopper is not used for a long time, it is recommended to completely disassemble the stopper, replace the sealing ring and lubricate

thoroughly. After reassembling the stopper, wipe the outer side of the ring that comes into contact with the inner side of the pipe.

23. Clean and lubricate the stopper bar and the sealing disk to provide smooth operation and to allow centering of the stopper during the expansion phase.

24. Position the stopping unit (L.) on the slide gate valve.

25. Perform the same operations on the second fitting and install the by-pass between the two valves of the stopper machines. Equalize the pressure (M.) of the first slide gate valve. For this operation rotate **counter-clockwise** the knob that controls the equalizing valve until it stops.

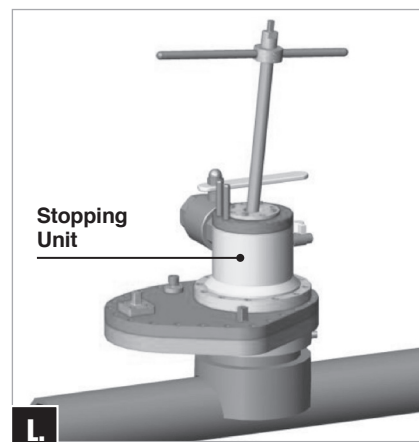

26. Open the slide gate valve.

27. Open the 2" stopping machine by-pass valve.

28. Open the 2" stopping machine by-pass valve located on the downstream stopping unit.

29. Purge the air in the by-pass through the drain valve located on the second stopping unit.

30. Open the second slide gate valve without acting on the internal pressure equalizer, as pressure is already equal above and below the plate.

31. Ensure the proper operation of the by-pass line and check for leaks.

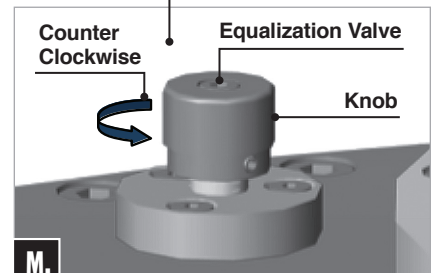
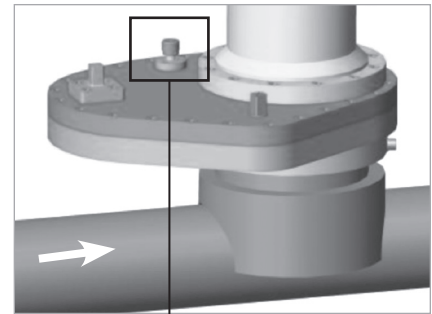

32. Lower the stopper and position the handle between the pins on the safety ring, oriented along the axis of the pipe.

33. Turn the ratchet handle **clockwise** and gradually expand the sealing ring of the stopper. During this operation slide the rod from top to bottom and vice versa to properly position the stopper in the pipe (N.).

34. Tighten the safety ring (O.).

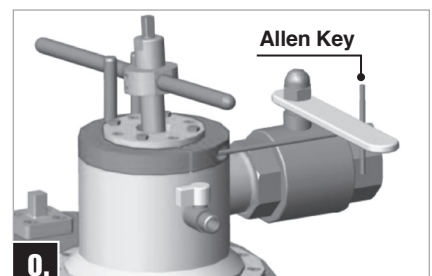
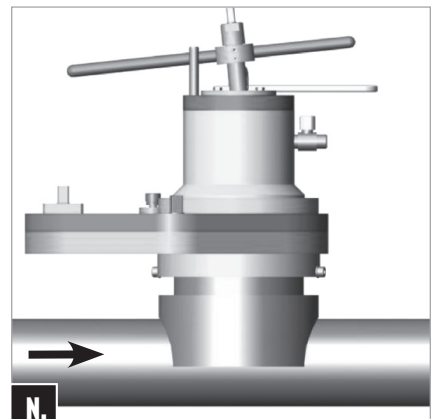

MUELLER® Shur Stop™ PE Line Stopping System

Operating Instructions

35. Expand the sealing ring to obtain a positive seal. DO NOT over-tighten.

36. Repeat the same operations on the second stopper unit.

37. Purge remaining gas through No. 1 and No. 2 (P.). In case of abnormal leakage from one of two stoppers, it is appropriate to remove it for inspection of the sealing ring, equalizing the upstream and downstream pressure of the stopper, before decompressing the stopper.

38. Make the repairs.

39. Before decompressing the sealing ring it is necessary to equalize the pressure upstream and downstream of the stopper (Q.).

When only gas comes out of vent No. 2, close the respective gate letting the gas equalize pressure. It is now possible to test the new connections (R.).

40. Decompress the sealing ring of the stopper by operating **counter-clockwise** on the ratchet handle until a hard stop and retract the stopper inside the stopping unit.

41. Repeat the same operations on the second stopping machine (S.).

42. Close the related slide gate valves (T.). Bleed the gas contained in the by-pass at a suitable distance from possible sources of ignition.

43. Remove the by-pass and the stopping units (U.).

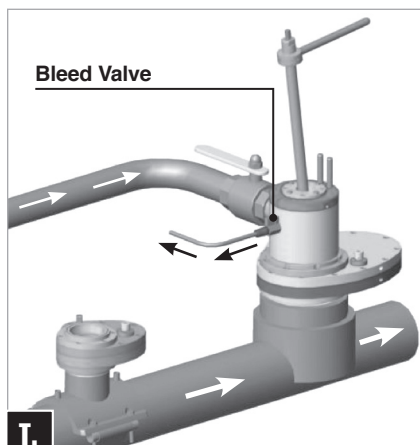
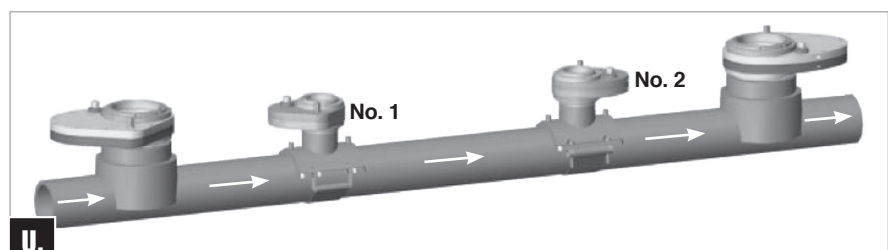
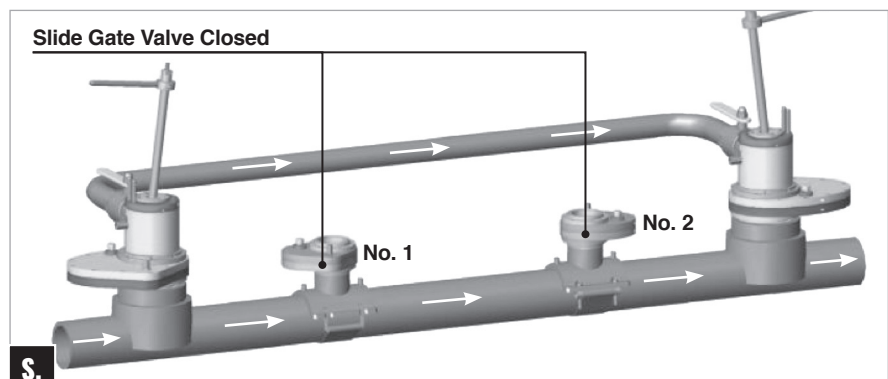
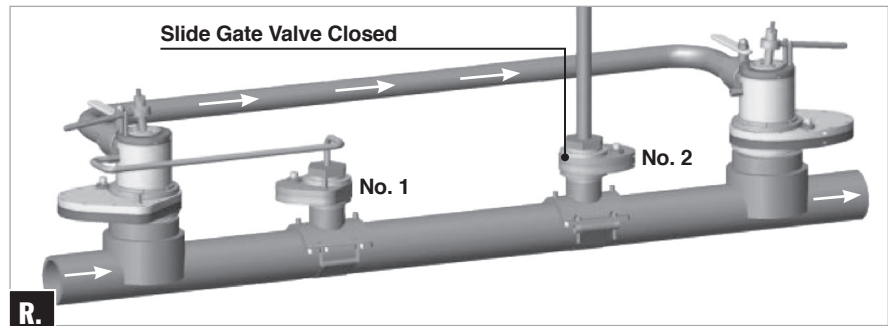
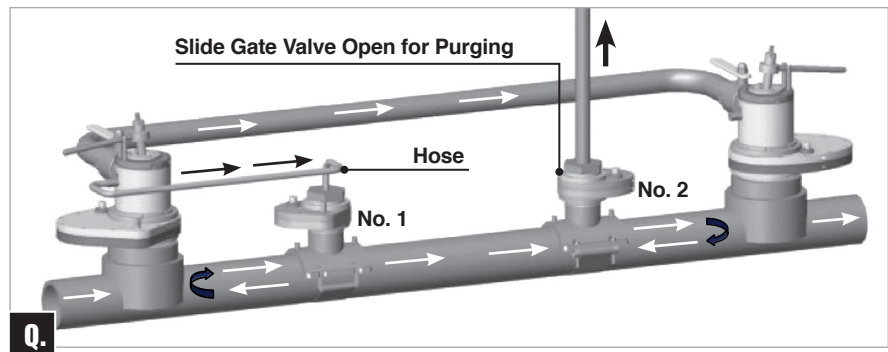
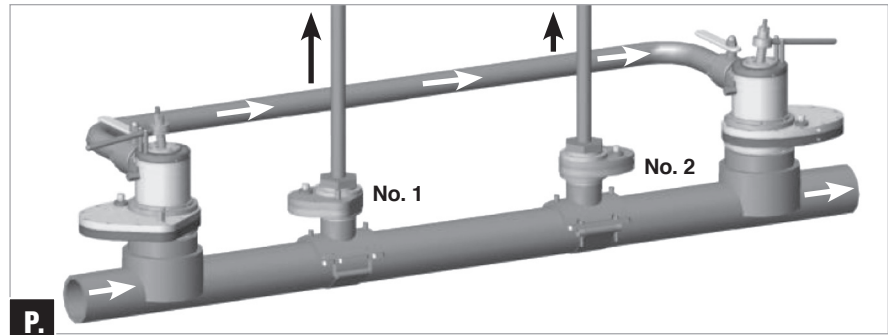

MUELLER® Shur Stop™ PE Line Stopping System

Operating Instructions

PREPARATION OF DRILLING MACHINE TO INSERT THE COMPLETION PLUG

1. Remove the cutter holder, cutter and pilot bit from the drilling shaft.
2. Replace the drilling shaft (A.) with the plug holder shaft.

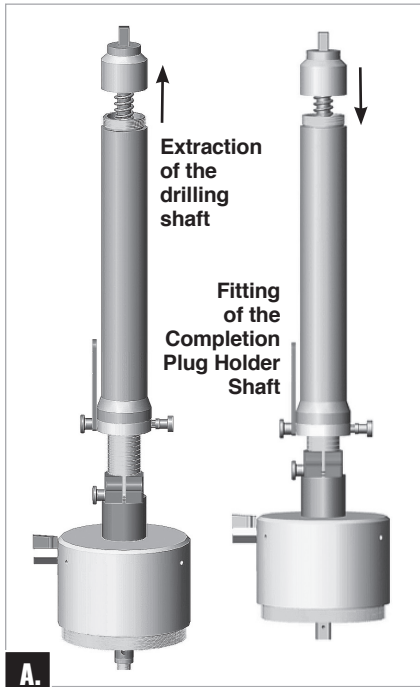

3. Thread the completion plug tool onto the completion plug by aligning up to two of the four holes. Tighten the locking set screws securely (B.).

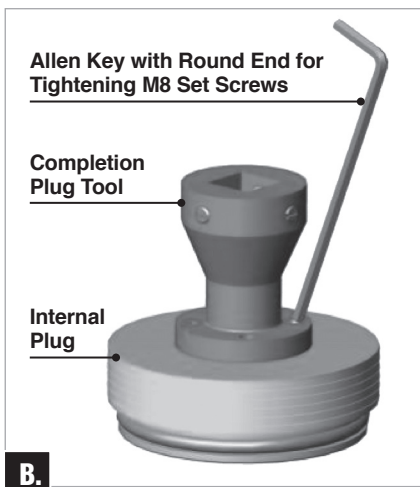

4. Now insert the completion plug holder onto the completion shaft and tighten the spring detents (C.).

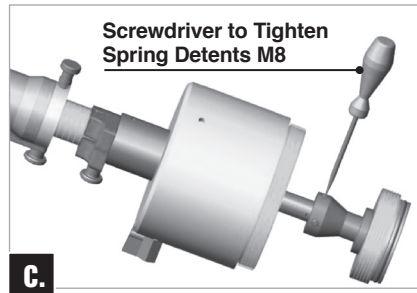

5. Insert the safety pin on the completion plug holder shaft (D.).

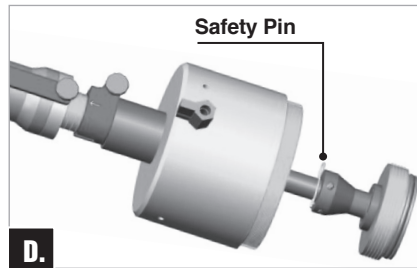

6. Lubricate the O-ring of the internal plug with PURITY-FG Spray or equivalent and retract the plug into the machine adapter.

7. Assemble the completion machine on the slide gate valve, open the equalization valve and then open the slide gate valve.

8. Lower the completion plug until it rests on the seat of the fitting threads and compress the spring to about 1/10" (see E. on page 8).

9. Install the ratchet handle (see F. on page 8) and maintain a constant downward pressure of the spring until the plug is completely screwed in.

10. Bleed any residual pressure off using the bleed valve (see points 31-32 on page 10) and check the completion plug for any leaks.

11. Remove the ratchet handle and turn the completion machine feed tube counter-clockwise until the shaft is released from the completion plug holder.

12. Remove the completion machine, the slide gate valve and the completion plug holder. Remove the completion machine, the slide gate valve and the completion plug tool (E.).

NOTE: In the event that difficulties arise in the removal of the slide gate valve, use the operating wrench on the square flat plate to assist (E1.).

13. Install all completion caps (F.).

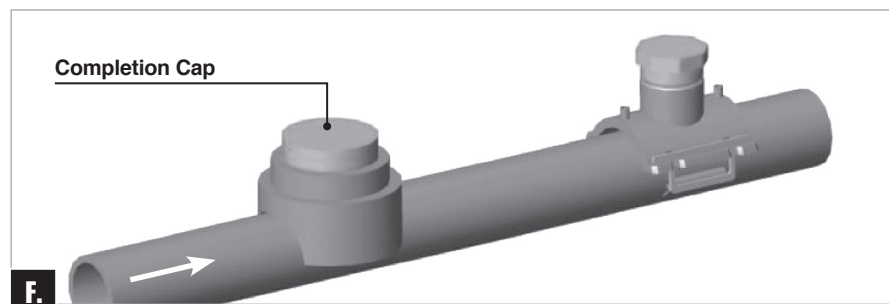
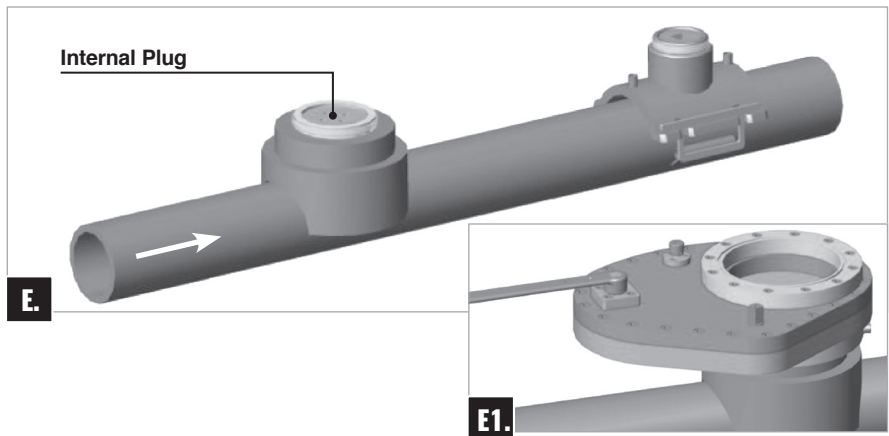

Preparation of Drilling Machine to Remove the Completion Plug (4-6")

COMPLETION PLUG EXTRACTION INSTRUCTIONS

1. Remove drilling bar shaft from the Unit 46 machine and replace with the completion/extraction bar. **(A)**

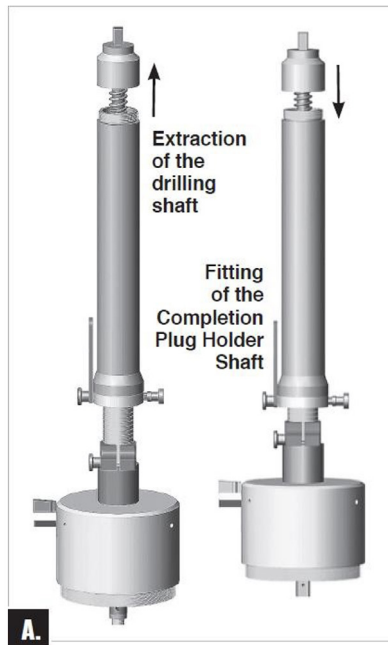

2. Thread the extraction tool fully onto the completion plug, aligning two of the four holes. It may be necessary to unthread the tool slightly to align holes. Tighten the locking set screws securely with allen key. **(B)**

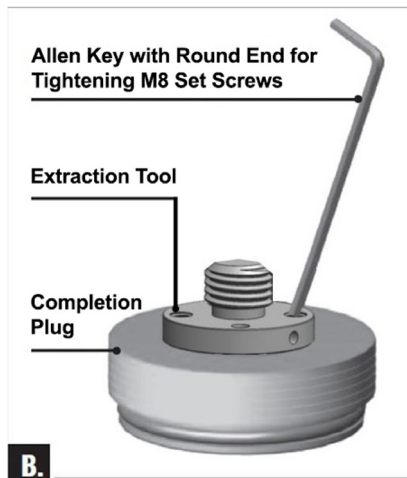

3. Install the extraction bar adapter onto the completion/extraction bar and tighten the spring detents. **(C.)**

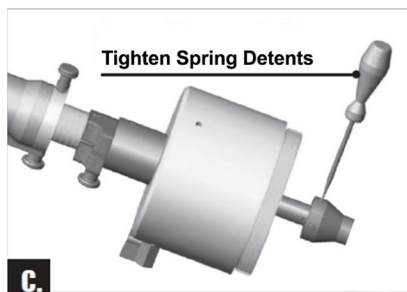

Preparation of Drilling Machine to Remove the Completion Plug (4-6")

COMPLETION PLUG EXTRACTION INSTRUCTIONS

4. Insert the safety pin into the completion/extraction bar (**D**)

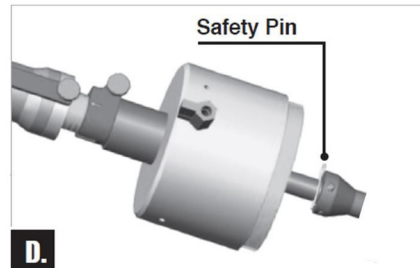

5. Fully retract the completion/extraction bar and adapter into the machine housing.
6. Attach Unit 46 gate valve to the fitting using appropriate adapter.
7. Attach the completion machine onto the Unit 46 gate valve. Equalize the pressure above the completion plug from an external source through the machine relief valve.
8. Advance completion/extraction bar downward by rotating feed tube clockwise until adapter contacts the top of the extraction tool and compresses the spring to about an 1/8" gap. (**E**)

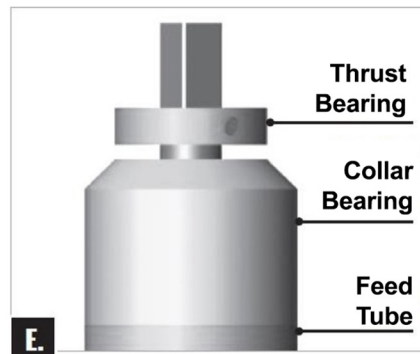

9. Install the ratchet handle on the top operating nut of the extraction bar.

Thread the extraction bar adapter onto the extraction tool that is connected to the completion plug. This is performed by turning the ratchet handle counterclockwise. Be sure to turn the feed tube clockwise (F) to provide constant downward pressure while maintaining an 1/8" gap between thrust bearing and thrust collar. Continue until the extraction tool adapter is completely threaded onto the extraction tool. Ratchet handle will stop rotating when fully engaged. (**F**)

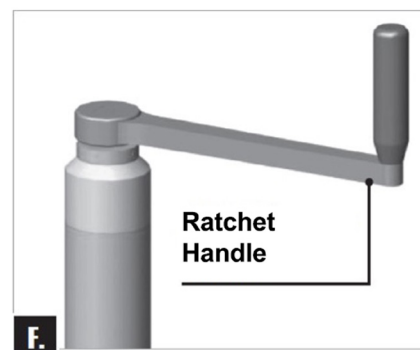

Preparation of Drilling Machine to Remove the Completion Plug (4-6")

COMPLETION PLUG EXTRACTION INSTRUCTIONS

10. Once the extraction tool is completely engaged, relieve tension on the spring by removing the 1/8" gap. Unthread the completion plug by turning counterclockwise with the ratchet handle and feed tube. Continue until the completion plug is extracted.
11. Remove the ratchet handle and continue turning the feed tube counterclockwise until the extraction bar is in its rearmost position.
12. Close the slide gate valve and purge pressure in the machine through the relief valve.
13. Remove the completion machine from the gate valve and disconnect the extraction tool and plug.

*Please note the extraction tool and extraction bar adapter have left-handed threads which will require turning clockwise to release.

MUELLER® Shur Stop™ PE Line Stopping System

Maintenance/Part Replacement

CLEANING

It is recommended to clean the various parts of the equipment after its use with a damp cloth and lubricate with neutral grease SKF LGMT 2.

Maintenance Instructions

It is recommended to replace the stopper sealing ring after every 10 stopping operations following the instructions below.

In case of non-use of the stopper sealing ring, replace it periodically

every 12 months from the date of delivery to your site.

The seals must be kept away from sunlight, either if they are installed on the equipment or in the warehouse as spare parts.

In any case they can be used no later than 1 year from time of receipt.

MAINTENANCE/PART REPLACEMENT

Sealing Ring Replacement

1. Remove the locking screws of the guard and remove it.
2. Slightly expand the sealing ring.
3. Unscrew the screw located on the crown bearing. The screw pitch is left handed (turn **clockwise** to loosen).
4. Rotate the ratchet handle **counter-clockwise** and pull out the front flange completely from its seat.
5. Remove the sealing ring.
6. Thoroughly clean the angled surfaces of the flanges and lubricate with PURITY-FG Spray or equivalent.

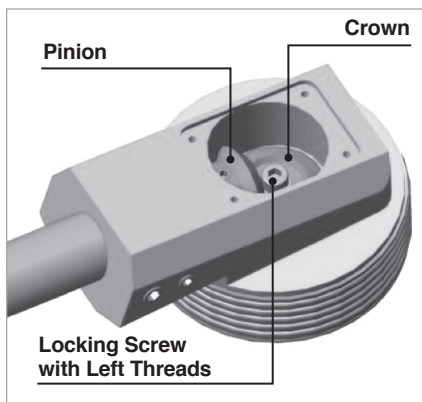

7. Lubricate the angled walls of the sealing ring with PURITY-FG Spray or equivalent and place the ring in place.

8. Attach the front flange, taking care to match the anti-rotation grooves between the two disks.

9. Rotate **clockwise** with the ratchet spanner to release the upper part of the pin from inside the crown.

10. Thoroughly clean the internal threads of the pin and tighten the screw **counter-clockwise** using liquid threadlocker (to screw rotate **counter-clockwise**).

11. Lubricate the gears with neutral grease, rotate **counter-clockwise** with the ratchet handle to the stop position.

12. Position the cover and tighten the screws.

13. Remove any residual spray or grease from the outer surface of the sealing ring.

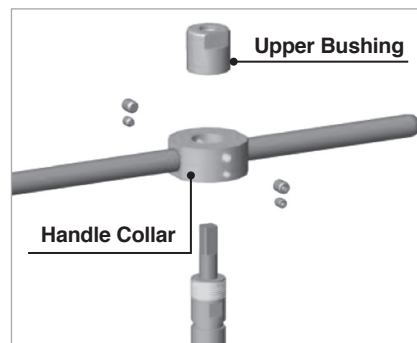

Replacement of Sealing Disk Between Stopper Bar and Stopper Bell

1. Unscrew the upper bushing from the stopper bar.

2. Unscrew the set screws of the handle collar and remove it.

3. Remove the stopper bar from the bell.

4. Loosen the (4) hex head screws of the closing flange of the sealing disk.

5. Remove the sealing disk cover and the related sealing disk.

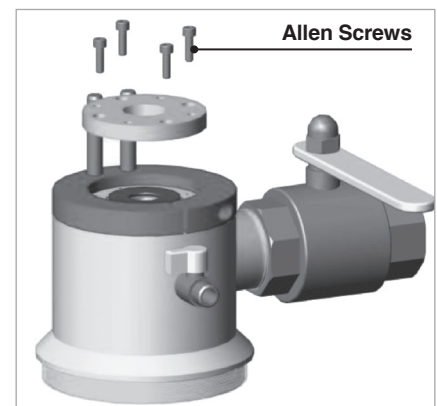
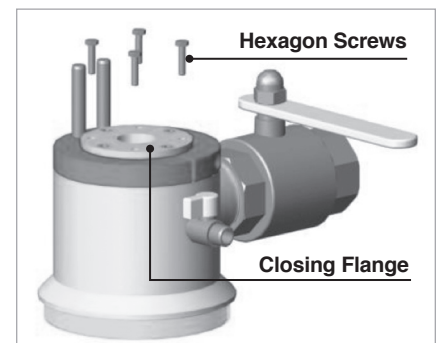

6. Thoroughly clean the seat of the sealing disk.

7. Position the new sealing disk.

8. Lubricate with PURITY-FG Spray or equivalent.

MUELLER® Shur Stop™ PE Line Stopping System

Maintenance/Part Replacement

9. Position the sealing disk cover.
10. Position the closing flange on the sealing disk.
11. Tighten the (4) hexagon head screws using the thread locker making sure that the sealing disk is not compressed.
12. Thread the (4) Allen screws without overtightening them.
13. Insert the stopper in the bell.
14. Reassemble the handle collar and then the upper bushing.

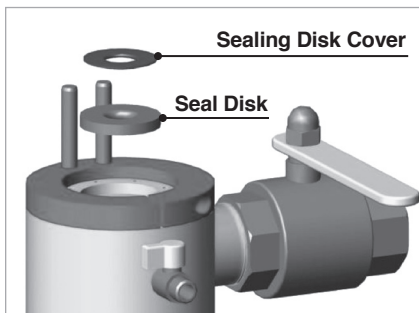

O-Ring Replacement at the Top of the Stopper

1. Unthread the upper bushing from the stopper pipe.
2. Remove the old O-rings.
3. Thoroughly clean the O-ring seats.
4. Fit the new O-rings in their seats.

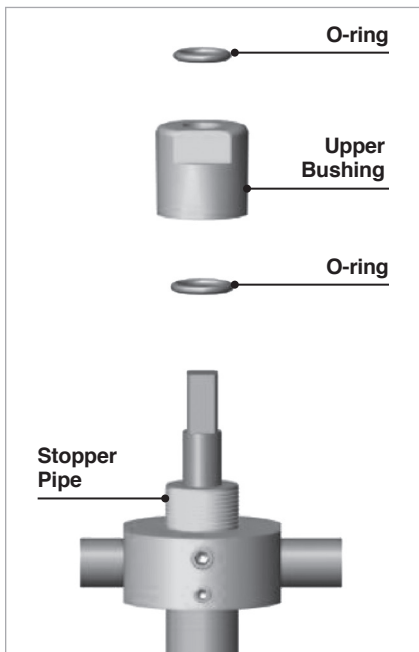

5. Lubricate with neutral grease.
6. Thread the upper bushing on the stopper pipe.

Slide Gate Valve O-rings replacement

1. Remove the upper flange and the lower flange.
2. Remove the screws that tighten the two valve bodies and separate them.
3. Separate the plate and the related control set screw from the lower valve body.
4. Replace the O-rings located on the flanges, on the valve bodies and on the operating square.
5. Generously lubricate the sliding surface of the plate, the plate and the operating square using neutral grease.
6. Place the plate into the sliding seat on the lower valve body centering the plate with the corresponding seat.
7. Remount the upper valve body and the upper and lower flanges.

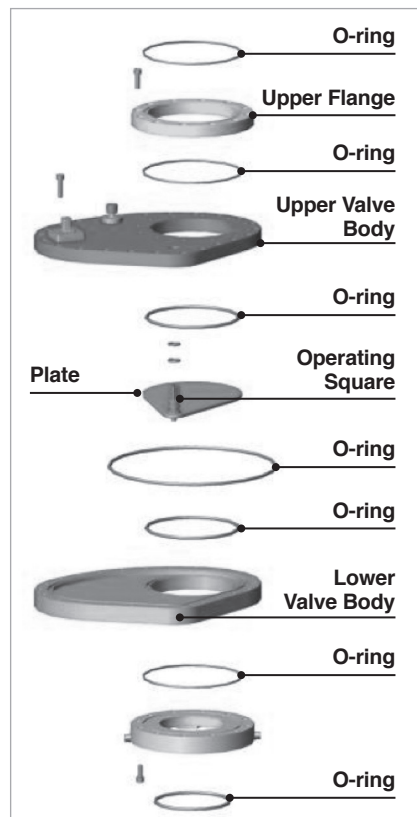

Replacement of Cleaning/Inspection Viewer O-ring

1. Disassemble the collar and remove the rod.

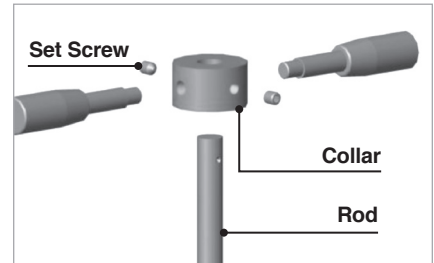

2. Loosen the (12) Allen screws and remove the closing flange.

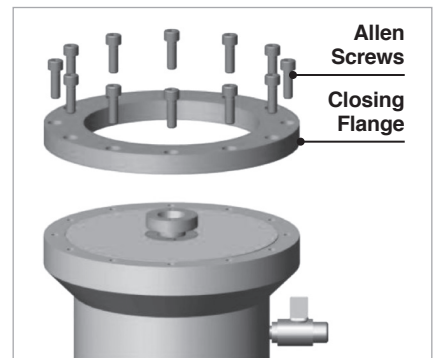

3. Unscrew the (2) countersunk Allen screws and remove the (2) half-rings.

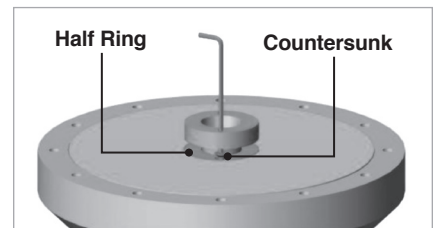

4. Remove the locking ring nut and remove the O-ring from the viewer. Pull out the viewer from the carrier.

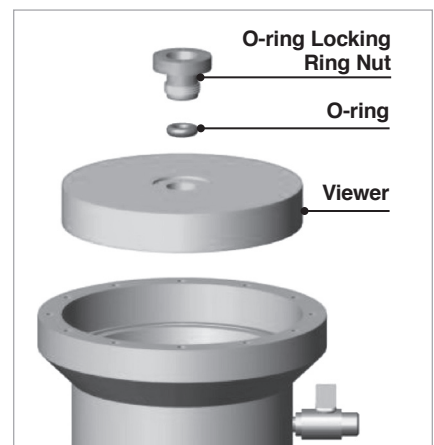

MUELLER® Shur Stop™ PE Line Stopping System

Maintenance/Part Replacement

5. Thoroughly clean the seat of the viewer O-ring;
6. Insert the new O-ring seal;
7. Reassemble the locking ring nut and the (2) half-rings;
8. Reassemble the viewer and the closing flange of the carrier;
9. Lubricate the rod with PURITY-FG Spray or equivalent and insert it in the viewer;
10. Reassemble the collar tightening the set screws with the thread lock liquid;
11. Tighten the locking ring nut until a slight compression of the O-ring seal on the shaft is obtained.

Replacement of the Tapered Roller Bearing of the Bushing

1. Loosen the cutter holder of the drilling shaft (or pull out the split pin from the plug holder shaft as shown below).

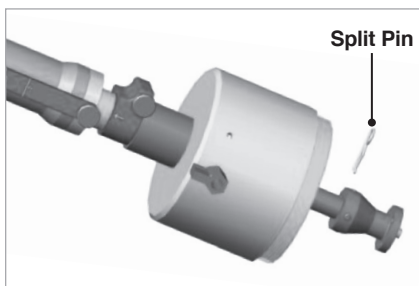
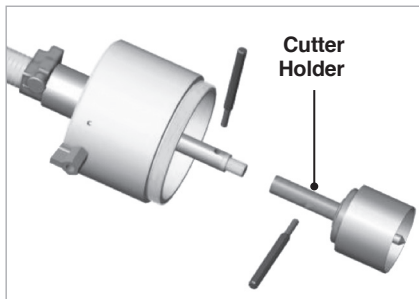

2. Loosen the bushing of the feed tube.
3. Pull off the roll pin from the lock washer.

4. Pull off the drilling shaft (or completion plug shaft) fitted with the spring.
5. Remove the tapered roller bearing.
6. Clean the bearing housing.
7. Lubricate the bearing with neutral grease.

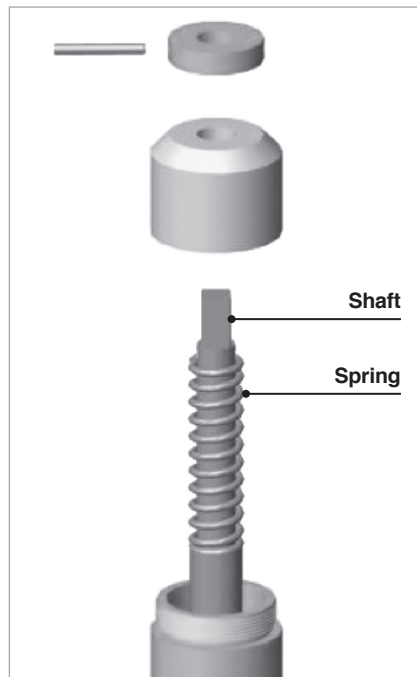
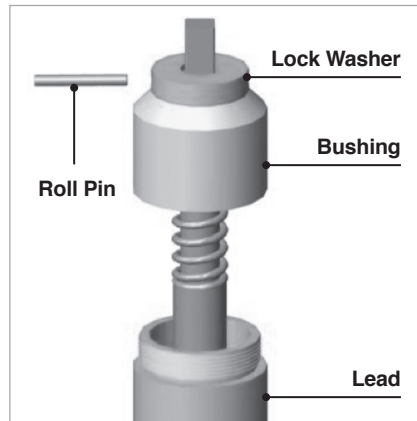

8. Thread the drilling shaft (or completion plug shaft) fitted with the spring in the bushing.
9. Fasten the lock washer with the spring pin.
10. Tighten the bushing to the lead screw.

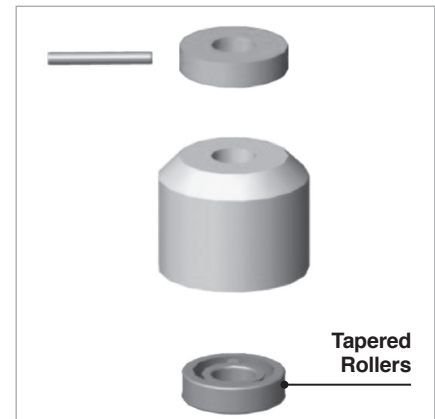

Replacement of the seals of the pipe drilling machine

1. Loosen the cutter of the drilling shaft (or remove the split pin from the thread plug holder shaft).
2. Unscrew the machine adapter from the feed screw.

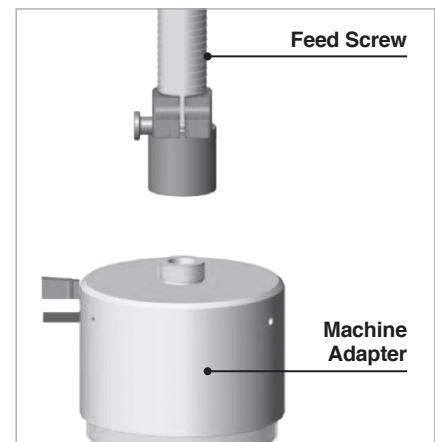

3. Loosen the feed tube from the feed screw by pulling the safety lock over the lock position.

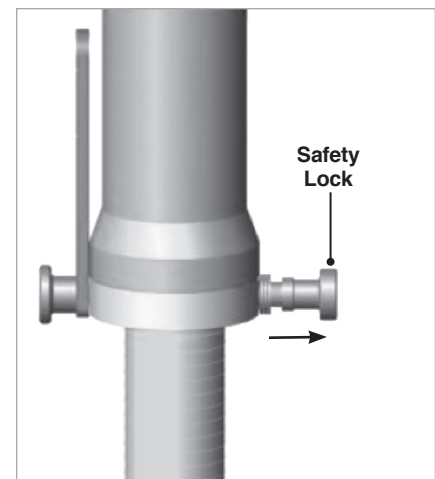

MUELLER® Shur Stop™ PE Line Stopping System

Maintenance/Part Replacement, Troubleshooting, and Storage

4. Remove the sealing ring and the O-rings from their seats (fig. 3-4).
5. Install the new sealing ring and the new O-rings.
6. Lubricate the seals with neutral grease.
7. Tighten the feed tube to the feed screw pulling the safety lock over the lock position.
8. Tighten the threaded fitting to the feed tube.

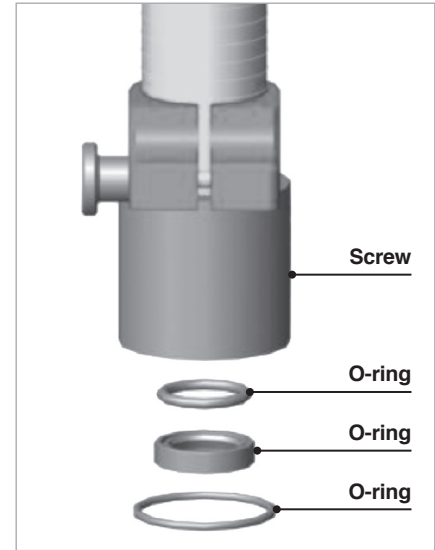
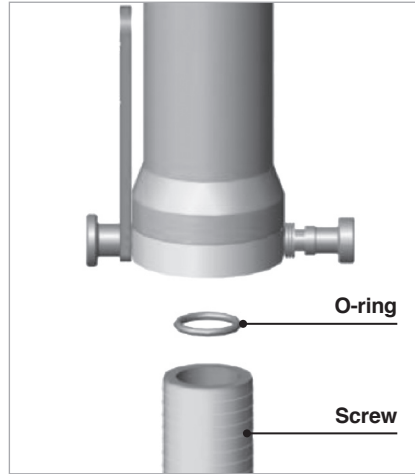

TROUBLESHOOTING

PROBLEM	CAUSE	SOLUTION
Drilling time too long	Worn cutter	Replace the cutter
Gas leakage between the drilling shaft and the screw	Worn O-rings	Replace the O-rings.
Inadequate sealing of the stopper	No lubrication performed on the angled walls of the sealing ring	Lubricate with PURITY-FG Spray or equivalent the angled walls of the sealing ring expanding and retracting it completely
Leakage around stopper bell	No lubrication performed on the sealing disk of the stopper bell	Lubricate the sealing disk with PURITY-FG Spray or equivalent.
Inadequate sealing of the stopper	Presence of debris on the bottom of the pipe	Clean again using the inspection/cleaning viewer
Inadequate sealing of the sealing disk	Insufficient tightening of the screws of the flange that presses the sealing disk	Tighten the screws slightly
Inadequate sealing of the valve	Equalization valve not closed	Close the equalization valve
	Residues on the sealing O-ring	Before the next use replace the O-rings

STORAGE

In case of long periods of inactivity, the equipment must be stored taking suitable precautions for the place it is stored in and the duration of the storage:

- Store the equipment in a closed place.
- Protect the equipment from humidity and extreme changes in the temperature.

- Prevent corrosive substances coming into contact with the equipment.



Gas (North America)
1.800.798.3131
www.muellergas.com
moreinfo@muellercompany.com